



TOWBAR INSTALLATION INSTRUCTIONS

PART NUMBER 03428XW

FORD RANGER MY22 C/C X-BAR



PRODUCT DETAILS:

Part Number:	03428XW	Maximum Towing Braked:	3500	kg
ECU Number:	WLE70029	Maximum Towing Unbraked:	750	kg
Tail Harness Length Required:	400 mm	Maximum Static Ball Load:	350	kg
TBM/Lug Part Number:	21339			
Wiring Part Number:	WLL90029			

FITTING DETAILS:

Towbar Installation Time:	60 Mins.	Hayman Reese SmartCODE Solution Required:	YES
Wiring Installation Time:	30 Mins.	RPA Disable/Other:	NO
Total Installation Time:	90 Mins.	Bumper Cut Required:	No

Note:

- Please refer vehicles owner's manual for proper operation and understanding of towing features enabled when coded.

CENTRE RECOVERY HOOK

CENTRE RECOVERY POINT LOADING MUST NOT EXCEED 8000kg.
DESIGNED FOR USE WITH A SNATCH STRAP NOT EXCEEDING
8000kg MBS (MINIMUM BRAKING STRENGTH).

8000kg



SIDE RECOVERY HOOK (SINGLE)

SIDE RECOVERY POINT LOADING MUST NOT EXCEED 4000kg
MBS (MINIMUM BRAKING STRENGTH).

4000kg



Warning: High torque requirements needed in installation.
Correct requirements must be followed to ensure trouble free
installation.



TOWBAR INSTALLATION INSTRUCTIONS

PART NUMBER 03428XW

FORD RANGER MY22 C/C X-BAR

ENSURE THAT INSTRUCTIONS ARE UNDERSTOOD PRIOR TO FITMENT.

i BEFORE YOU START:

Hayman Reese recommends that instructions are read completely prior to fitment. Check all hardware items have been included refer to assembly diagram. Please ensure this towbar is only fitted to vehicle models as per Hayman Reese application guide (www.haymanreese.com.au).

Bumper Cuts



Vehicle and bumper variations can and do occur during vehicle manufacture after initial towbar design. Fitment of towbar to vehicle and accuracy of bumper cut must be assessed prior to any bumper modifications made. Incorrect bumper cuts are not covered under Hayman Reese warranty.

NOTE: Bumper cuts need to be approached with care, refer to notes below.

- Bumper centreline – where the centreline of the bumper needs to be determined, the installer must assess centre point by measurement of bumper width or determining two symmetrical reference points to give centreline.
- Bumper edge – To assist with accurate bumper cut measurement, reference to the start of the bumper edge is now being commonly used.
 - Measure from bottom edge along bumper and around corner to the 70 mm point (Figure 1).
 - Do not measure from visible bumper front of corner, upwards (Figure 2).

Drilling

- For any required drilling during installation, ensure that the area is clear of fuel, electrical & other components that may be damaged.
- All holes drilled into the body panels shall have all burrs & swarf removed then coated with a suitable rust preventative paint.

Bolts/Fasteners

- Ensure that all hardware is fastened to correct torque as specified in this fitting instruction.
- All fasteners supplied with this product are used to achieve a specified clamp loading. If replacement is required ensure that fasteners of the same grade and class are used.



NOTE: Achieving correct torque is critical to proper installation and responsibility of the installer. Towbar failures attributed to tension issues from over tightening or under tightening are not covered by Hayman Reese warranty.

Product Labels

- Towbar load rating sticker provided with this product shall be conspicuously located on inside rear end of the driver's door.
- Powertrain Control Module (PCM)/Body Control Module (BCM) upgrade warning label will be provided in towbar kit for vehicles as required. Affix warning label in door and owner's handbook.

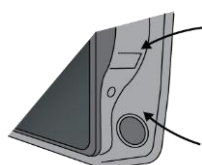

Place Load Rating sticker inside driver's door here

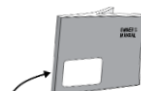

Place Vehicle PCM/ BCM upgrade warning label in door AND on front cover of owner's service handbook



WARNING:

Do not, drill, cut, weld or otherwise modify the towbar.

FOR TOWING PURPOSES ONLY - This towbar is designed and tested by Hayman Reese to adhere to ADR 62/02 which provides only for the expected load demands of towing.

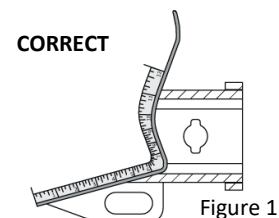

Figure 1

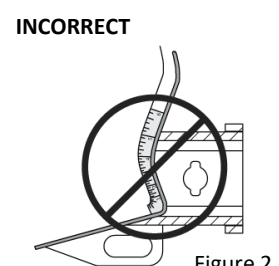

Figure 2



TOWBAR INSTALLATION INSTRUCTIONS

PART NUMBER 03428XW

FORD RANGER MY22 C/C X-BAR

i TOWBAR ASSEMBLY DIAGRAM

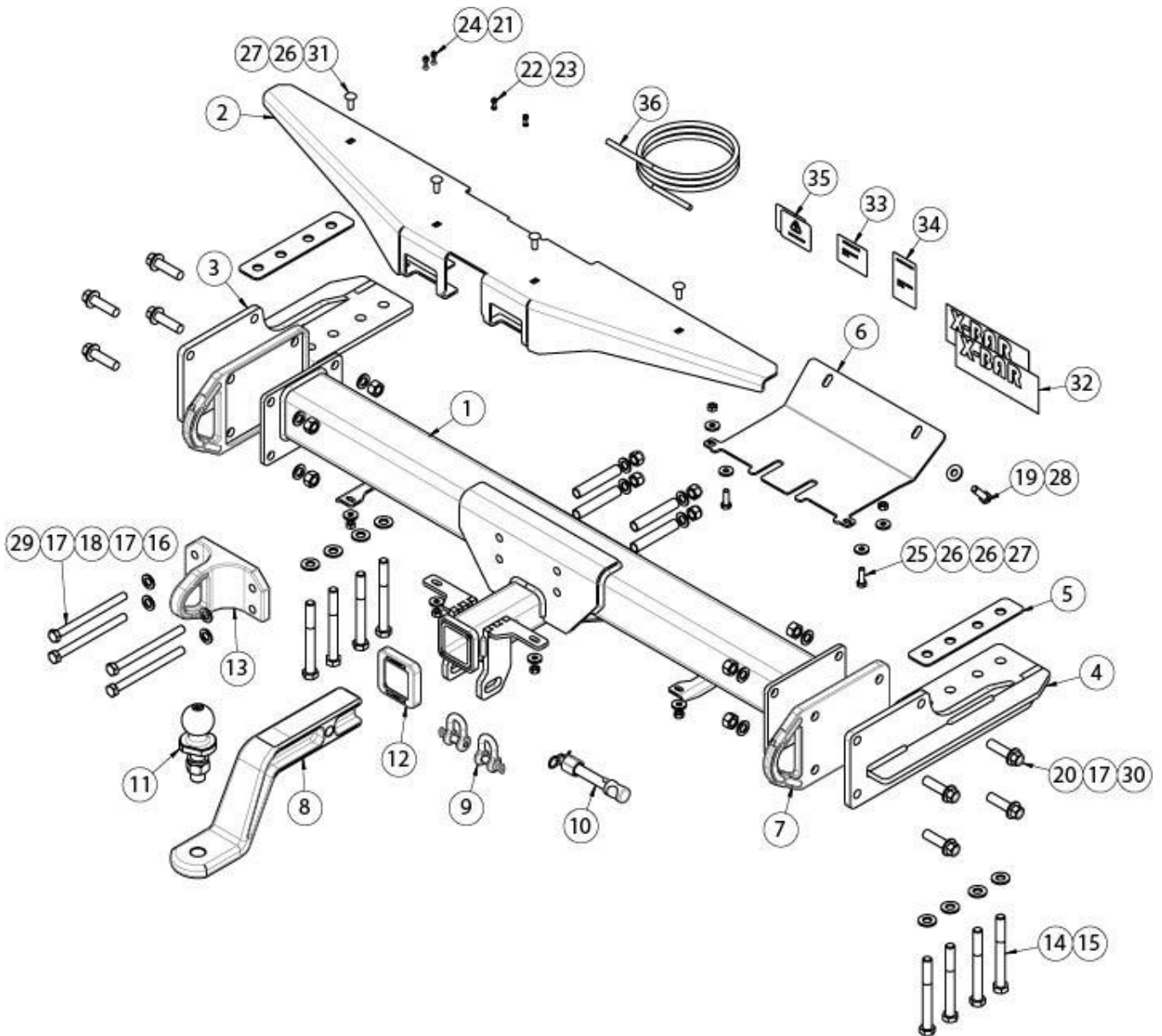



TOWBAR INSTALLATION INSTRUCTIONS

PART NUMBER 03428XW

FORD RANGER MY22 C/C X-BAR

ITEM	DESCRIPTION	QTY
1	XBAR MODEL B	1
2	BOLT ON PLATE - MODEL B	1
3	SIDE ARM ASSY, LH	1
4	SIDE ARM ASSY, RH	1
5	CHASSIS SPACER PLATE	2
6	BASH PLATE	1
7	FORGED SIDE RECOVERY PLATES	2
8	FORGED TBM EXTENDED DROP 3.5t	1
9	"D" SHACKLE 10mm	2
10	SMART PIN GOLD	1
11	TOWBALL 50mm	1
12	HITCH BOX COLLAR COVER	1
13	FORGED CENTRE RECOVERY MOUNT	1
14	BOLT HEX HD M14x130x2.0P	8
15	WASHER PLAIN M14x28x3	8
16	NUT HEX NYLON M12x1.75P	4
17	WASHER PLAIN M12x28x3mm	16
18	SPACER TUBE 90x16X1.6mm	4
19	BOLT HEX HD M10x35x1.25P	2
20	BOLT FLANGE HEX HD M14x50x2.0P	8
21	SCREW PAN HD M3x20x0.7P	2
22	NUT NYLOC HEX HD M4X0.7P	2
23	SCREW PAN HD M4x16x0.7P	2
24	NUT NYLOC HEX HD M3x0.7P	2
25	SET SCREW HEX HD M8x25x1.25P	2
26	WASHER PLAIN M8x22x3	8
27	NUT HEX HD M8x1.25P	6
28	WASHER PLAIN M10x25.4x3mm	2
29	SET SCREW HEX HD M12x150x10.9P	4
30	NUT HEX HD M14x2.0P	8
31	BOLT COACH M8x20x1.25P	4
32	XBAR DECAL STICKER	2
33	COMPLIANCE LABEL	1
34	LOAD RATING LABEL	1
35	CAN MODULE WARNING LABEL	2
36	WIRING LOOM	1



TOWBAR INSTALLATION INSTRUCTIONS

PART NUMBER 03428XW

FORD RANGER MY22 C/C X-BAR

1. Loosely secure the RH side arm assembly to the underside of the chassis rail with 4 x M14 bolts complete with 1 x washer per bolt.

Repeat for other side.

NOTE: If required, use the spacer plate between the chassis rail and the side arm if the chassis rail weld seam protrudes onto the mounting surface.

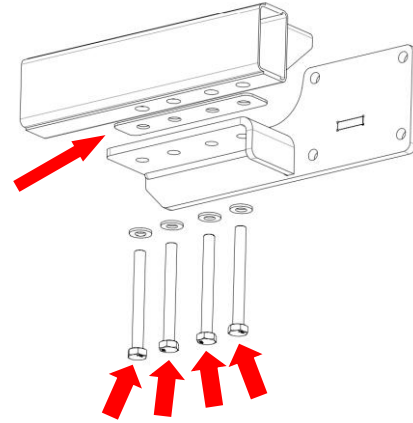

2. Using two people, lift the crosstube assembly up to the side arms ensuring to sandwich red recovery side plate between side arms and cross tube and loosely secure to the side arms with 4x M14 bolts complete with 1 x washer and 1 x nut per bolt.

Note: Red recovery side plates must have recess facing inwards.

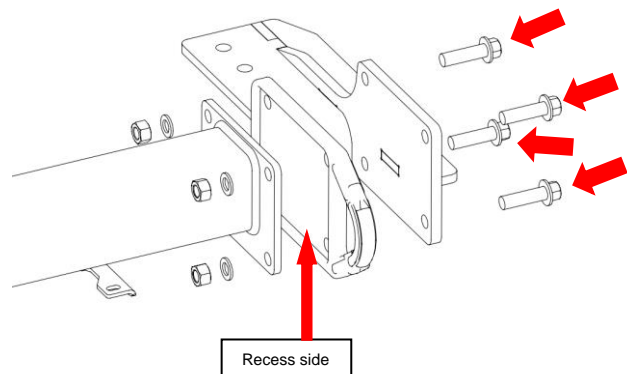

3. Refer to sequence A, B, C, and D on pages 6 and 7 for final assembly instructions.
4. Tighten all bolts to the torques listed below:
M8: 22 N.m ; M10: 48 N.m; M12: 140 N.m; M14: 175 N.m

IMPORTANT: Ensure all bolts are secured to correct torques using a calibrated torque wrench. Tighten side arms to chassis rail first in an even pattern/sequence. Repeat for centre section to side arms and finally torque all other fasteners.



TOWBAR INSTALLATION INSTRUCTIONS

PART NUMBER 03428XW

FORD RANGER MY22 C/C X-BAR

A. FIT PLUGS TO PLUG BRACKETS

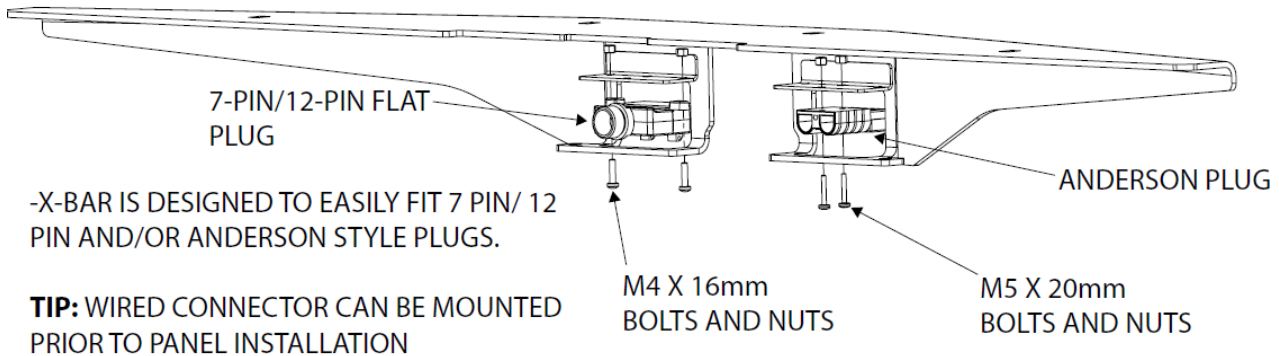

B. BOLT COVER PLATE TO TOWBAR

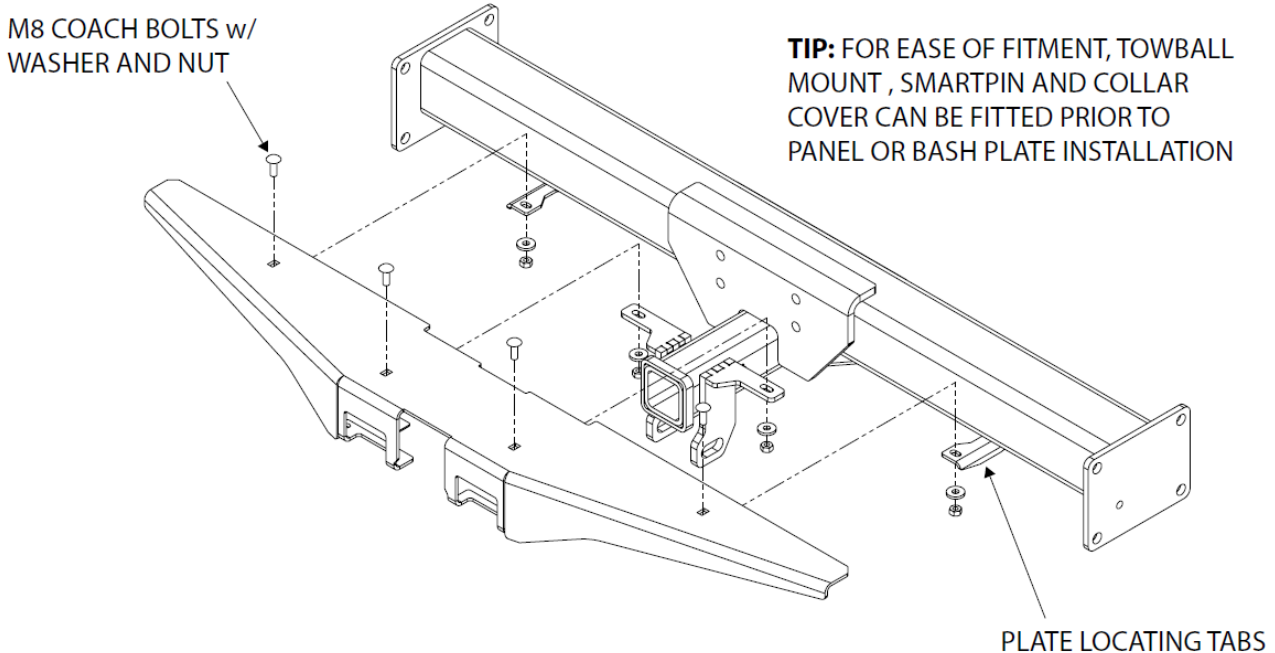



TOWBAR INSTALLATION INSTRUCTIONS

PART NUMBER 03428XW

FORD RANGER MY22 C/C X-BAR

C. BOLT CENTRE RECOVERY HOOK TO TOWBAR

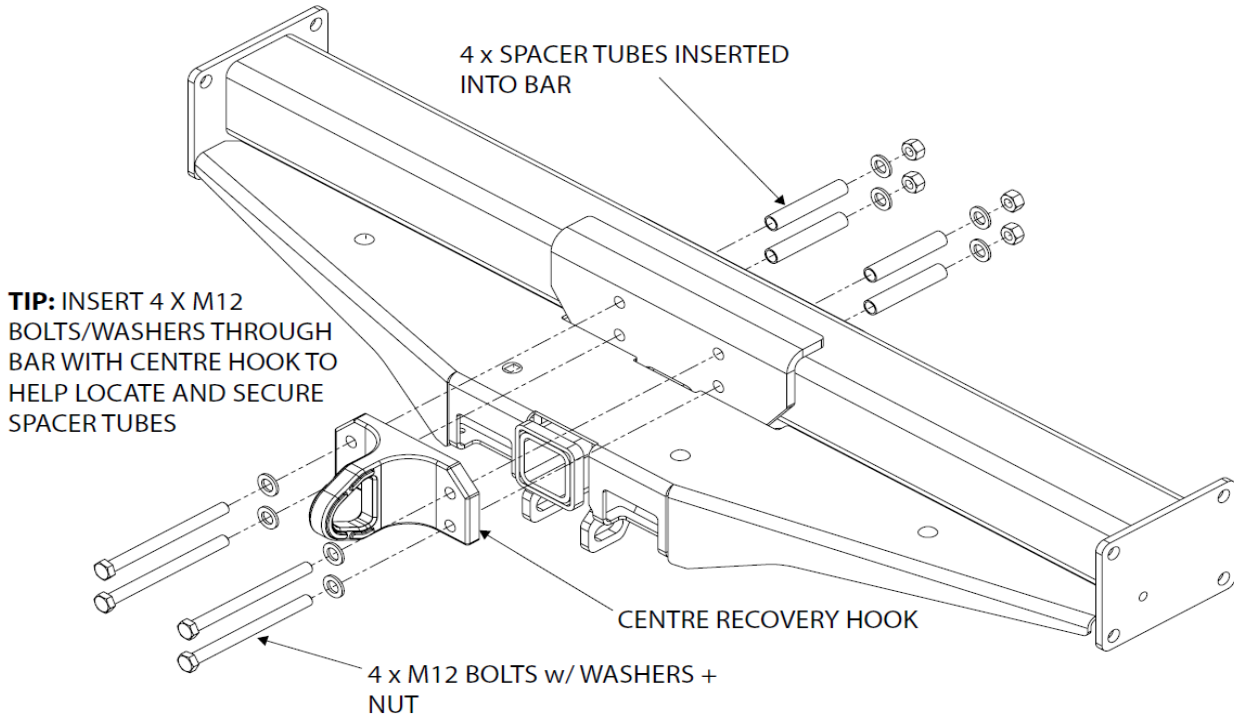

D. BOLT BASH PLATE TO TOWBAR

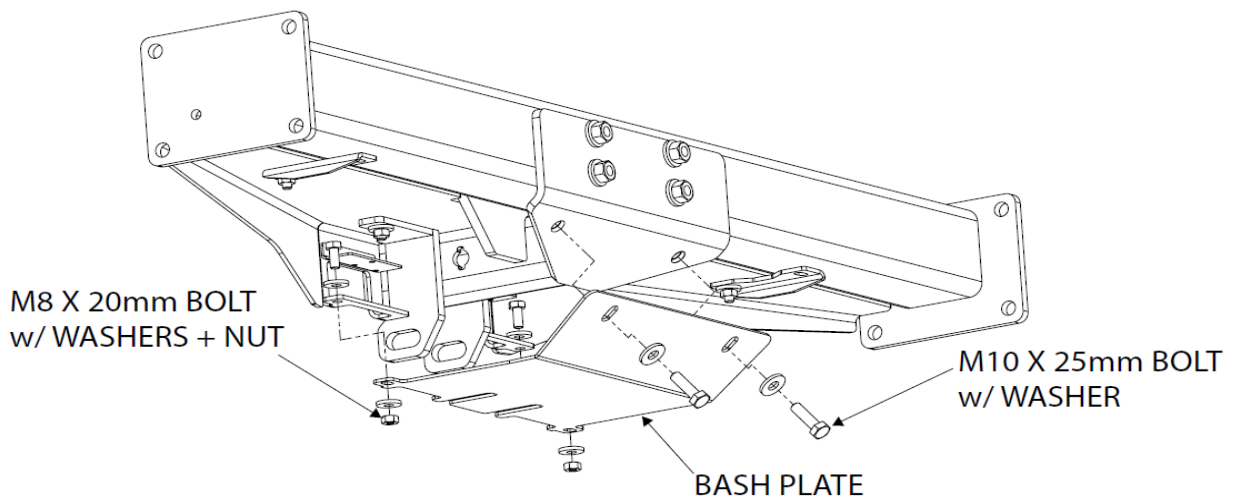



TOWBAR INSTALLATION INSTRUCTIONS

PART NUMBER 03428XW

FORD RANGER MY22 C/C X-BAR

5. On the LHS under carriage, locate and disconnect the blanking connector from the 16-way trailer output Pre-Wire connector.

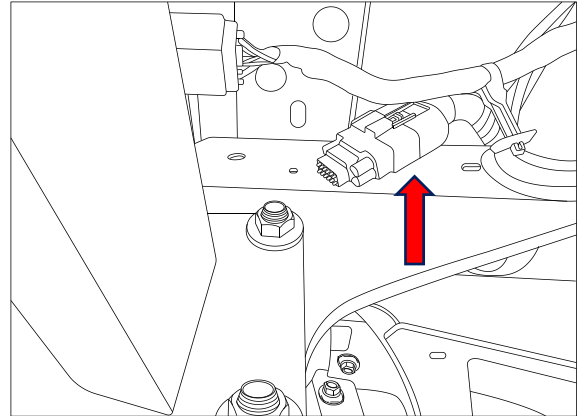

6. Connect the trailer patch (WLL90029) to the vehicle mating connector.
7. Mount the trailer plug to plug bracket, route the tail blue connector towards trailer patch mating connector.
8. Connect and waterproof the blue connector.

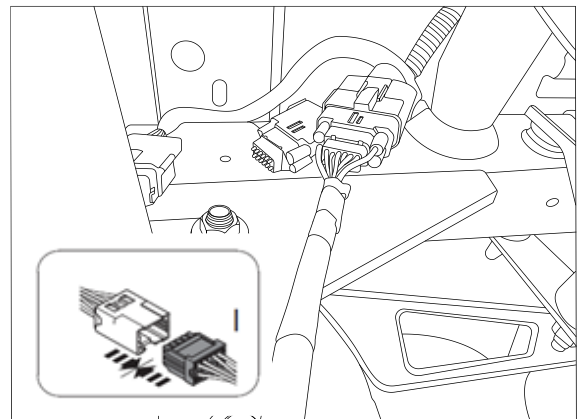

9. From inside the LHS of vehicle remove the following interior trims.

- Dislodge the door seal.
- Remove and detach the glove box. **(when open pull in the side stoppers).**
- Remove the end dash trim.
- Remove the fastener that's secures the front fascia trim, unclip the trim.

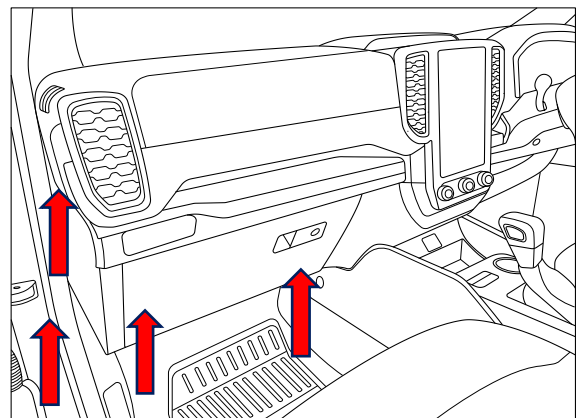



TOWBAR INSTALLATION INSTRUCTIONS

PART NUMBER 03428XW

FORD RANGER MY22 C/C X-BAR

10. Remove the Gateway module 3x fasteners.
11. Move the module enough to gain access the the trailer Pre-wire connectors.

Note: Care must be taken when moving the module.

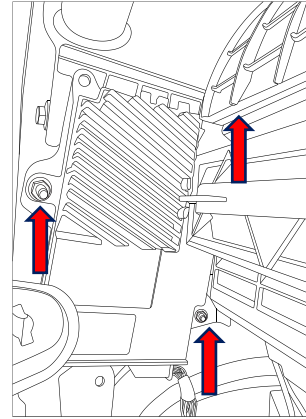

12. Using a flat blade screw driver release the connector tabs for the 3x trailer prewire connectors.

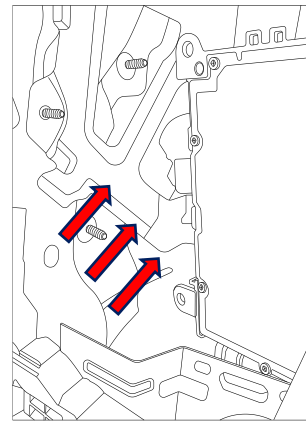

13. From underneath the LHS footwell pull down the released connectors.

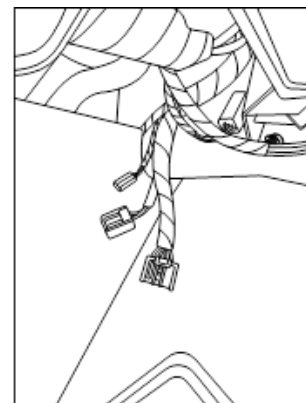



TOWBAR INSTALLATION INSTRUCTIONS

PART NUMBER 03428XW

FORD RANGER MY22 C/C X-BAR

-
14. Connect the trailer patch (WLL90029) interior harness to mating connectors.

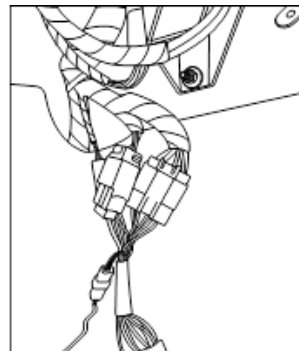

-
15. Connect the trailer Module (WLE70029) to mating 18-way connector.
16. Remove the ecu adhesive backing tape and secure the module in behind the LHS footwell.

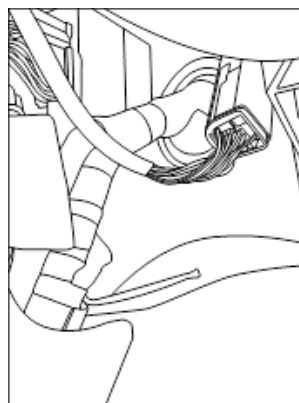

-
17. Refit all removed parts from steps 8- 11 in reverse.
18. Test the functionality of trailer module ensuring all lights work using a trailer test board.
19. Next step is coding of vehicle.
20. Pay attention to the "SmartCODE" instruction page.
21. Once vehicle is coded test trailer functionality with a test board.

Place fitting instructions in glovebox when finished.



CUSTOMER INFORMATION

PLACE THESE INSTRUCTIONS IN THE
VEHICLE'S GLOVEBOX AFTER INSTALLATION

THANK YOU FOR PURCHASING HAYMAN REESE.

**WITH CORRECT MAINTENANCE AND CARE THIS PRODUCT WILL PROVIDE A LIFETIME OF
TROUBLE-FREE OPERATION.**

i TOWBAR MAINTENANCE AND CARE:

1. Hayman Reese recommend that the towbar LUG or TBM (tow ball Mount) Pull Pin and R-clip are removed and stored when not in use. Removal of LUG or TBM (tow ball mount) is advisable when not in use to assist with any of the following.
 - Ensure rear number plate is not obscured.
 - Allow maximum available departure angle and prevent any potential interference.
 - Prevent possible interference with vehicles reverse sensors or camera detecting a tow ball mount as an obstruction during reversing.
 - Removes towball mount as an obstruction for when moving around the rear of the vehicle.
2. Hayman Reese recommends routine inspection of your towbar to ensure trouble free towing.
 - Bolt security and tension should be regularly inspected and checked for correct tension. Replace any worn or defective parts with suitable grade & class fasteners. Inspection should be requested to coincide with vehicle major services.
3. It is the owner's responsibility to ensure towing and down ball weight capacities of the towing vehicle are not exceeded.
 - Towing and down ball weights allowable may differ according to model variations. Please refer to owner's manual or vehicle dealer to confirm exact rating for your vehicle model variant.
 - It is not uncommon for the vehicle tow rating to differ from the towbar rating. When this occurs, the lesser rating must be adhered to.
 - For vehicles fitted with enhanced vehicle functions that may be altered/changed when towing i.e Trailer sway mitigation, blind spot detection, adaptive cruise control etc. Please consult owner's manual to understand changes enabled when towing and after towing.

WARRANTY INFORMATION:

Hayman Reese Towbars are covered by a Lifetime Warranty.

Our goods come with guarantees that cannot be excluded under the Australian Consumer Law. You are entitled to a replacement or refund for a major failure and for compensation for any other reasonably foreseeable loss or damage. You are also entitled to have the goods repaired or replaced if the goods fail to be of acceptable quality and the failure does not amount to a major failure.

For further details please visit www.haymanreese.com.au/warranty or contact customer service on 1800 812 017 or info@haymanreese.com.au.



CUSTOMER INFORMATION

PLACE THESE INSTRUCTIONS IN THE VEHICLE'S GLOVEBOX AFTER INSTALLATION

HAYMAN REESE SMART PIN

Your Hayman Reese towbar is equipped with Smart Pin technology to help reduce towbar tongue rattle in most driving conditions. Please ensure below instructions are understood and routine maintenance is carried out to ensure best towing experience.

i Regularly inspect for wear and check the tightness of the Smart Pin Nut. Follow instructions below to re-tighten the nut as necessary when movement and noise in the tow ball mount is noted.

- Before towing, ensure R-Clip is properly installed and Smart pin nut is installed and tensioned. Replacement parts are available from your Hayman Reese Distributor.

TOWBALL MOUNT REMOVAL/INSTALLATION

STEP 1 Insert Trailer Ball Mount (TBM) (a) into towbar hitchbox (b), aligning hole in TBM shank (c) with hole in hitchbox (d) (Fig. 1)

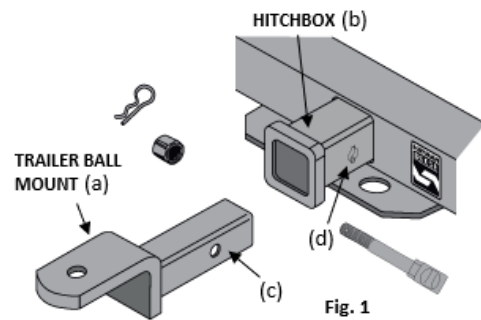

STEP 2 Insert Smart Pin (e) through hole in hitchbox and hole in TBM shank (g); ensure the locators are inserted into the notches in the hitchbox (Fig. 2)

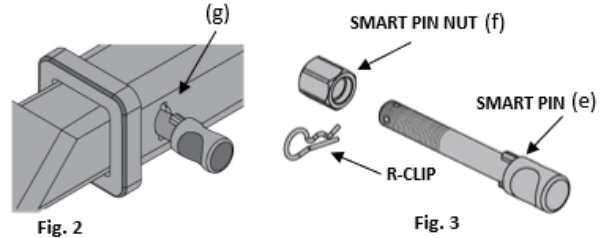

STEP 3 Screw Smart Pin Nut (f) onto Smart Pin (g); tighten Smart Pin Nut until finger tight, ensuring TBM is restrained from up and down movement.

STEP 4 Tighten Smart Pin Nut by turning nut a further 1/8th of a turn in the clockwise direction using a 24mm spanner (Fig. 4).

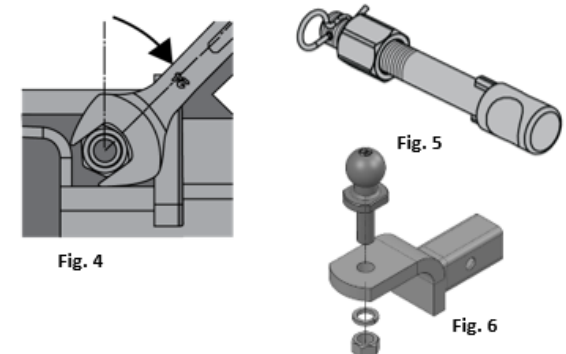

STEP 5 Install Smart Pin R-Clip through the hole that provides best clearance or easiest access. (Fig. 5)

STEP 6 Install towball onto TBM and tighten to **350 Nm** using a calibrated torque wrench (Fig. 6).

Appendix



WARNING: This vehicle requires a system setting to ensure the trailer wiring and control module are correctly recognised. This process (referred to as 'coding') must be carried out to enable correct vehicle functionality when trailer is connected. Towing features enabled by correct control module and coding support OE functionality as set by OE manufacturer. Please read the vehicles owner's manual for proper operation and understanding.

Coding can be carried out using the Hayman Reese SmartCODE (HRSC) using the following steps. Note, if HRSC is unavailable, vehicle coding can be carried out by OE manufacturer as needed.

Before you start:

- **Ensure the HRSC software is up to date using the HAYMAN REESE SMARTCODE PC APP.**
 - **Ensure the vehicle battery is fully charged**
 - **Use of a battery support unit (BSU) is advised during the coding process.**
 - **Ensure towbar, wiring loom and ECU are correctly installed as per Hayman Reese fitting instructions.**
1. Locate the OBD2 port under the drivers footwell on the right-hand side and plug in the HRSC.
 2. Close all doors and turn the ignition on
 3. Follow the directions on the screen of the HRSC
 4. Once the vehicle has been coded successfully proceed to the "clear codes" tab
 5. Remove disconnect HRSC from OBD2 port.
 6. Check the dash to make sure there are no warning faults.
 7. Check the operation of trailer lights and ensure the Reverse Park Assist (RPA) is disabled and 'trailer on' icon is active where available.

For technical support and further information on Hayman Reese SmartCODE tool and coding process contact your nearest Hayman Reese stockist.

Australia: 1800 812 017

New Zealand: 0800 237 886