

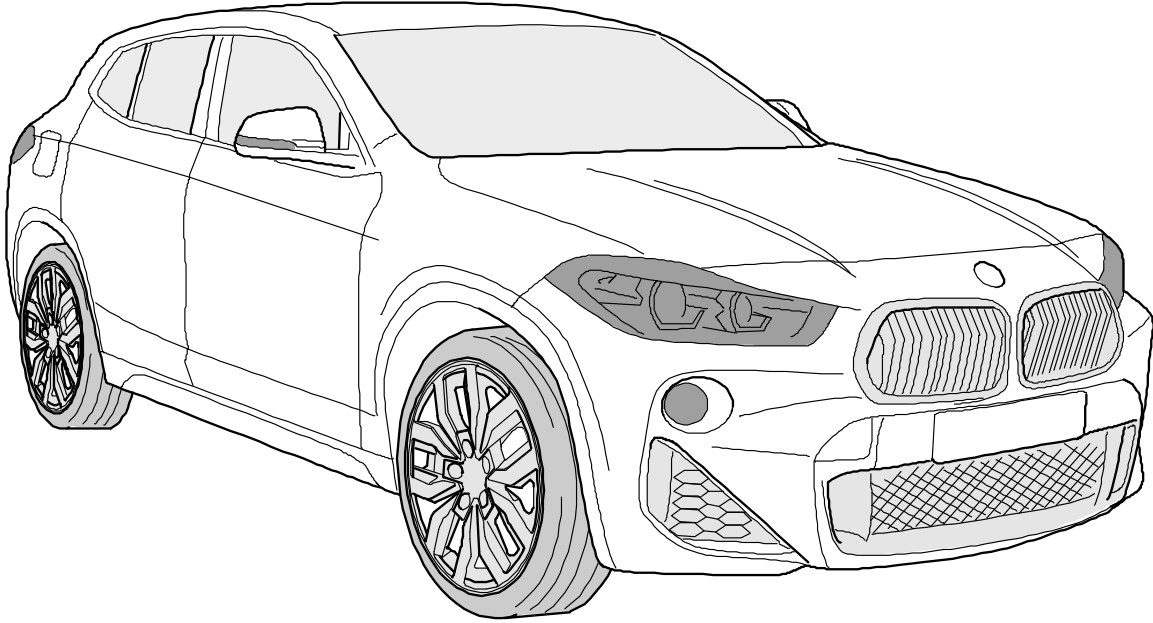

TOWBAR INSTALLATION INSTRUCTIONS

PART NUMBER 03340RW

BMW X2 F39 CL4



PRODUCT DETAILS:

Part Number:	03340RW	Maximum Towing Braked:	2000	kg
ECU Number:	WLE70019	Maximum Towing Unbraked:	750	kg
Tail Harness Length Required:	1800 mm	Maximum Static Ball Load:	75	kg
TBM/Lug Part Number:	21201			
Wiring Part Number:	WLL90018			

FITTING DETAILS:

Towbar Installation Time:	145 Mins.	Hayman Reese SmartCODE Solution Required:	NO
Wiring Installation Time:	45 Mins.	RPA Disable/Other:	YES
Total Installation Time:	190 Mins.	Note:	
Bumper Cut Required:	Yes	<ul style="list-style-type: none">Electric Brake = Brake Prep Connector	



TOWBAR INSTALLATION INSTRUCTIONS

PART NUMBER 03340RW

BMW X2 F39 CL4

ENSURE THAT INSTRUCTIONS ARE UNDERSTOOD PRIOR TO FITMENT.

i BEFORE YOU START:

Hayman Reese recommends that instructions are read completely prior to fitment. Check all hardware items have been included refer to assembly diagram. Please ensure this towbar is only fitted to vehicle models as per Hayman Reese application guide (www.haymanreese.com.au).

Bumper Cuts



Vehicle and bumper variations can and do occur during vehicle manufacture after initial towbar design. Fitment of towbar to vehicle and accuracy of bumper cut must be assessed prior to any bumper modifications made. Incorrect bumper cuts are not covered under Hayman Reese warranty.

NOTE: Bumper cuts need to be approached with care, refer to notes below.

- Bumper centreline – where the centreline of the bumper needs to be determined, the installer must assess centre point by measurement of bumper width or determining two symmetrical reference points to give centreline.
- Bumper edge – To assist with accurate bumper cut measurement, reference to the start of the bumper edge is now being commonly used.
 - Measure from bottom edge along bumper and around corner to the 70 mm point (Figure 1).
 - Do not measure from visible bumper front of corner, upwards (Figure 2).

CORRECT

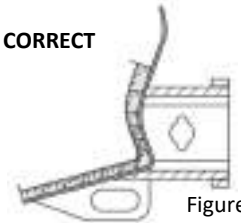

Figure 1

INCORRECT

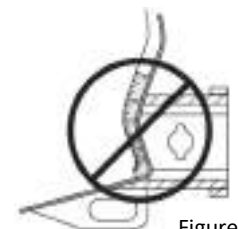

Figure 2

Drilling

- For any required drilling during installation, ensure that the area is clear of fuel, electrical & other components that may be damaged.
- All holes drilled into the body panels shall have all burrs & swarf removed then coated with a suitable rust preventative paint.

Bolts/Fasteners

- Ensure that all hardware is fastened to correct torque as specified in this fitting instruction.
- All fasteners supplied with this product are used to achieve a specified clamp loading. If replacement is required ensure that fasteners of the same grade and class are used.



NOTE: Achieving correct torque is critical to proper installation and responsibility of the installer. Towbar failures attributed to tension issues from over tightening or under tightening are not covered by Hayman Reese warranty.

Product Labels

- a. Towbar load rating sticker provided with this product shall be conspicuously located on inside rear end of the driver's door.
- b. Powertrain Control Module (PCM)/Body Control Module (BCM) upgrade warning label will be provided in towbar kit for vehicles as required. Affix warning label in door and owner's handbook.



Place **Load Rating sticker** inside driver's door here

Place **Vehicle PCM/ BCM upgrade warning label** in door AND on front cover of owner's service handbook



WARNING:

Do not, drill, cut, weld or otherwise modify the towbar.

FOR TOWING PURPOSES ONLY - This towbar is designed and tested by Hayman Reese to adhere to ADR 62/02 which provides only for the expected load demands of towing.



TOWBAR INSTALLATION INSTRUCTIONS

PART NUMBER 03340RW

BMW X2 F39 CL4

TOWBAR ASSEMBLY DIAGRAM

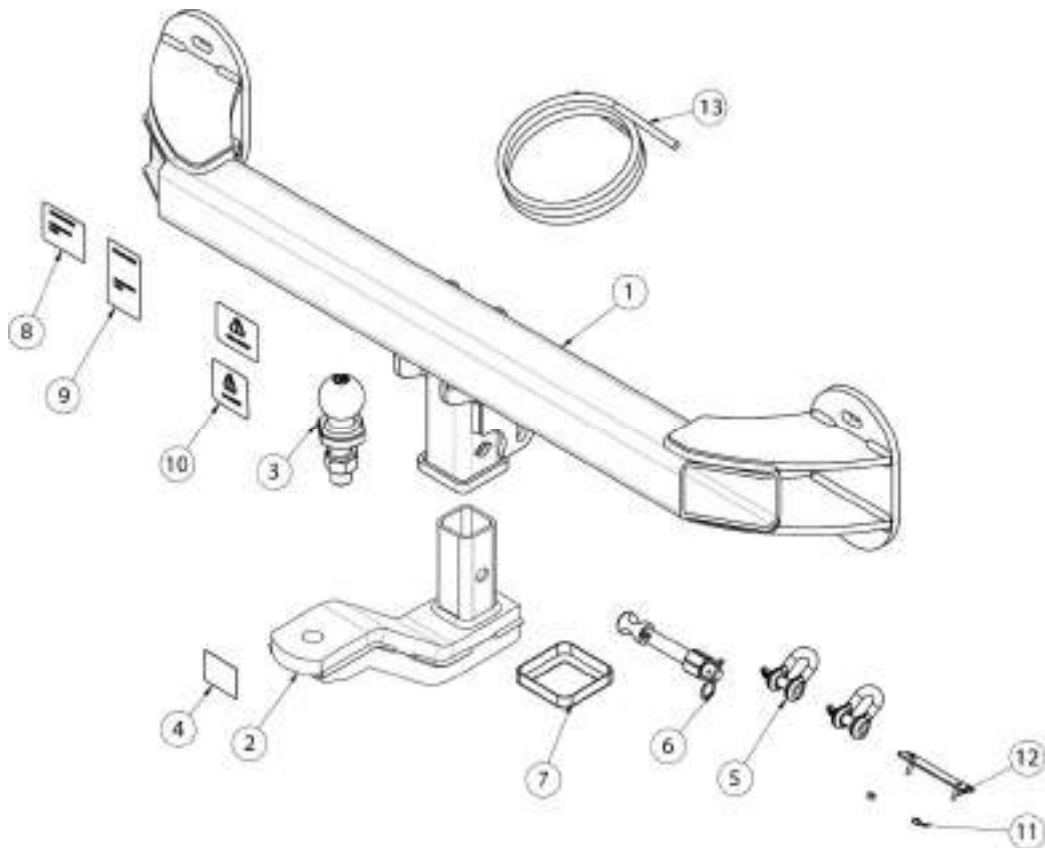

ITEM	DESCRIPTION	QTY
1	BMW X2 WELDED ASSEMBLY	1
2	TRAILER BALL MOUNT	1
3	TOWBALL 50mm	1
4	HAYMAN REESE LOGO STICKER	1
5	"D" SHACKLE 10mm	2
6	SMART PIN GOLD	1
7	HITCH BOX COLLAR COVER	1
8	COMPLIANCE LABEL	1
9	LOAD RATING LABEL	1
10	CAN MODULE WARNING LABEL	2
11	NUT NYLOC HEX HD M4X0.7P G8	2
12	PLUG BRACKET	1
13	WIRING LOOM	1



TOWBAR INSTALLATION INSTRUCTIONS

PART NUMBER 03340RW

BMW X2 F39 CL4

WIRING ASSEMBLY DIAGRAM

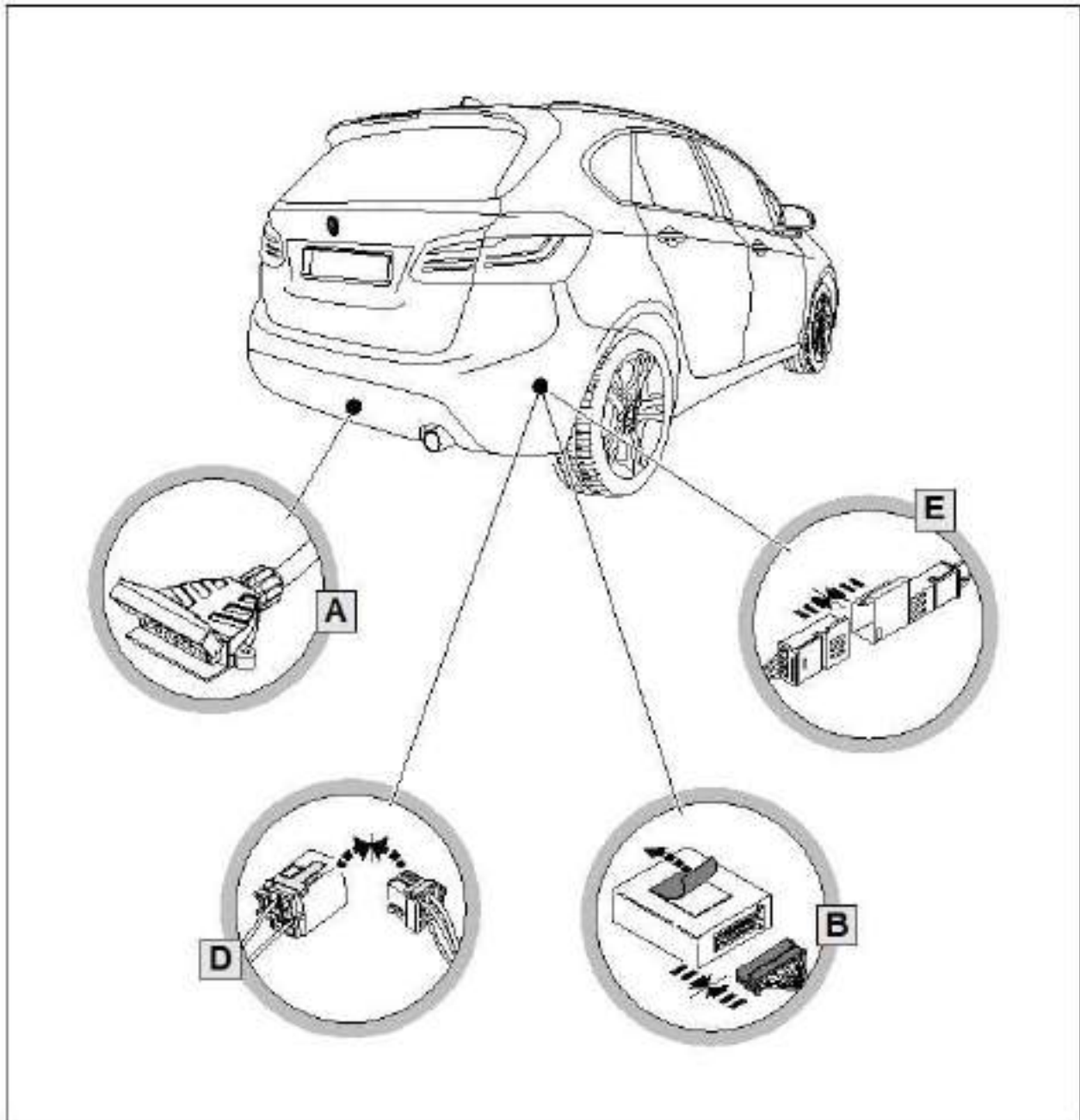



TOWBAR INSTALLATION INSTRUCTIONS

PART NUMBER 03340RW

BMW X2 F39 CL4

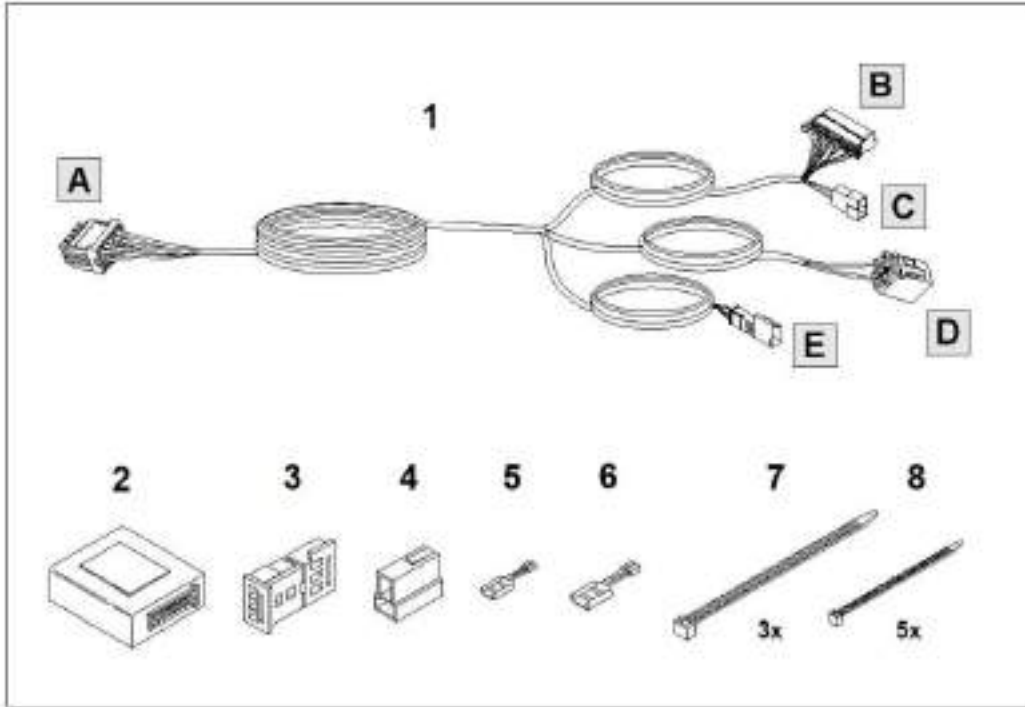

ITEM	DESCRIPTION	QTY
1	Main Harness	1
2	Trailer module -> WLE70019	1
3	CAN 3-pin housing	1
4	Brake controller 2-pin housing	1
5	Brake controller plug pin - small	1
6	Bake controller plug pin - large	1
7	Cable tie 300mm	3
8	Cable tie 150mm	5

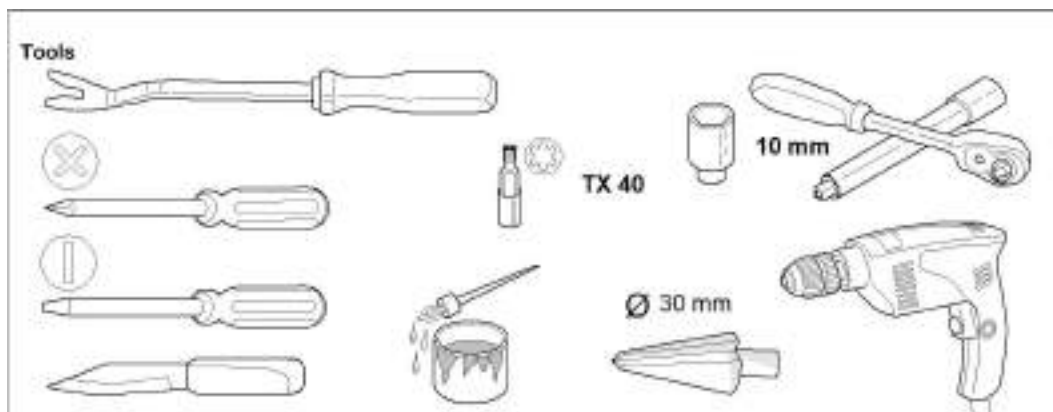



TOWBAR INSTALLATION INSTRUCTIONS

PART NUMBER 03340RW

BMW X2 F39 CL4

1. Open the tailgate.

Remove taillight covers
Remove 2x nuts.

Repeat for the other side.

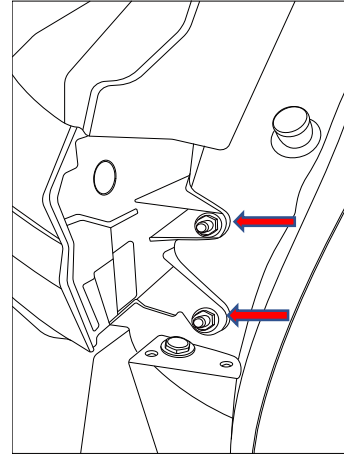

2. Remove 6x screws from under bumper.

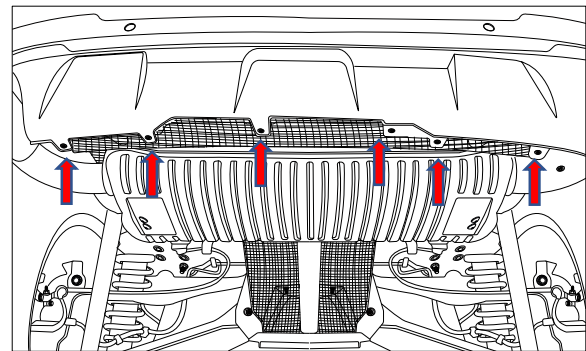

3. Remove 3 x plastic rivets from wheel arch.

Repeat for the other side.

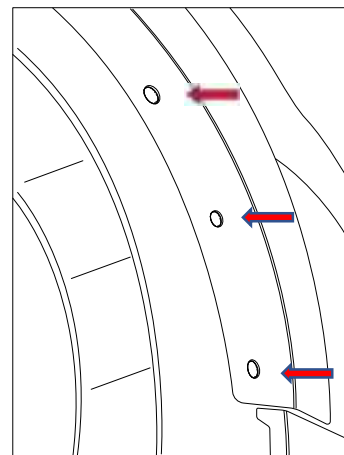



TOWBAR INSTALLATION INSTRUCTIONS

PART NUMBER 03340RW

BMW X2 F39 CL4

4. Peel back wheel arch
Remove 2x screws on the side and 1x screw underneath.

Repeat for the other side.

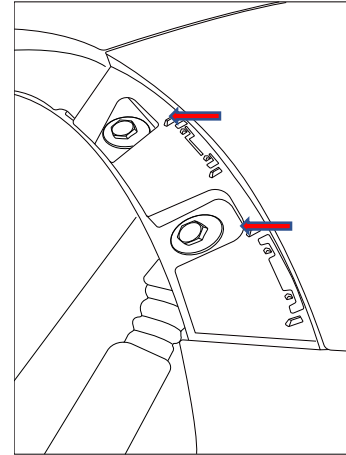

5. Slowly remove bumper, disconnect 4x sensor plugs, 1x number plate lights plug and 1x camera plug.

Note: If vehicle is fitted with foot swipe then disconnect the plu prior to removal of the bumper fascia.

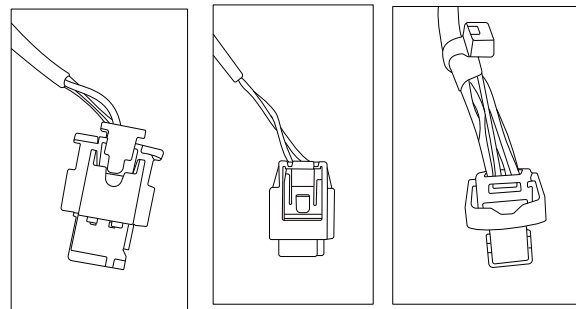

6. Remove and discard the impact beam. **Retain 4x nuts.**

Remove the heatshield.
Mark and cut out an area 410mm horizontally at centre line and vertically up to the fold line.

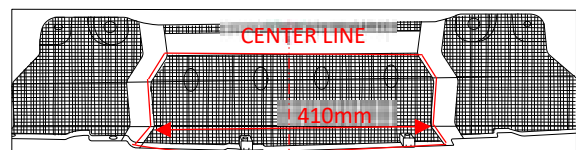
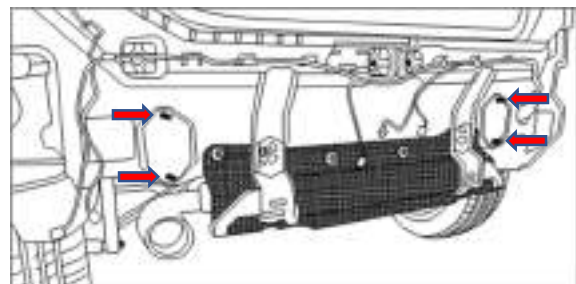



TOWBAR INSTALLATION INSTRUCTIONS

PART NUMBER 03340RW

BMW X2 F39 CL4

- Loosely fit towbar to vehicle with 4x nuts from impact beam.
Adjust the towbar to the center of the vehicle and then torque the nuts

Torque specification.

M12 – 120 Nm

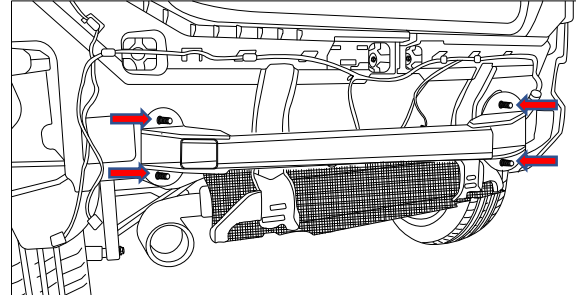

IMPORTANT

Due to possible vehicle variations, always confirm any noted vehicle colour wires with a multi-meter to ensure the correct function is identified before soldering or scotch locking. For vehicle wires denoted with two colours (example; RED/GREEN) the first colour will always be the main wire colour while the second colour is the thinner trace colour on the wire.

- Open the rear tailgate remove the rear sunshade.
- Remove the boot floor cover.

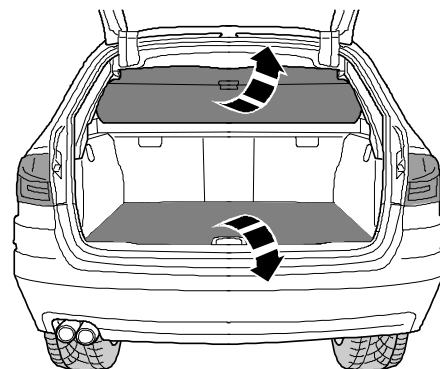



TOWBAR INSTALLATION INSTRUCTIONS

PART NUMBER 03340RW

BMW X2 F39 CL4

-
10. Remove the boot sill trim by firstly removing the 3x scrivet.

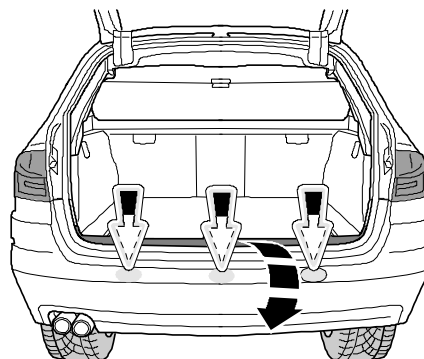

-
11. Remove the 2x anchor points.
12. Remove the boot light out and disconnect.
13. Locate the RHS rear cargo net and dislodge the lower frame from the plastic storage tub.

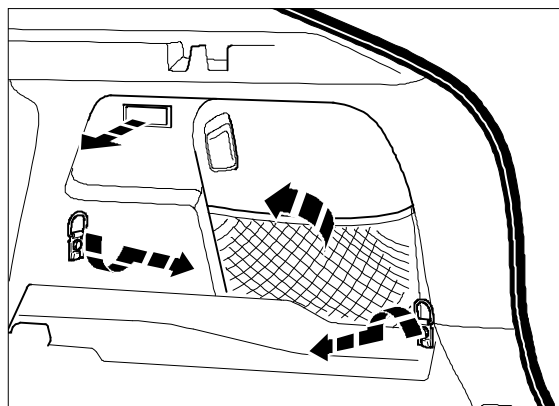

-
14. Remove the plastic storage tub.

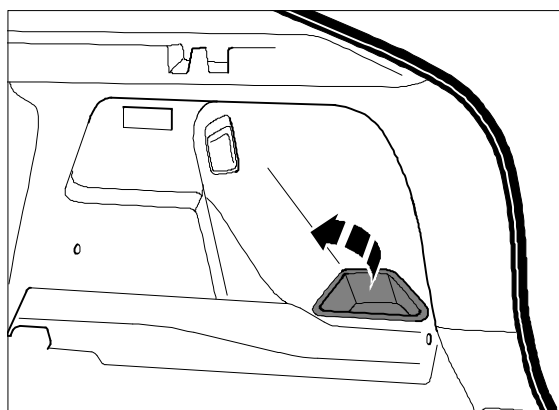



TOWBAR INSTALLATION INSTRUCTIONS

PART NUMBER 03340RW

BMW X2 F39 CL4

15. Remove the rear RHS passenger sill trim.
16. Dislodge the C-pillar trim and move to the side.

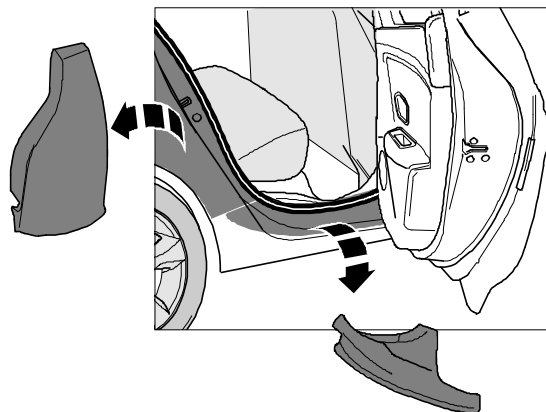

17. Dislodge the rear RHS boot trim by pulling outward from the bottom towards the centre of the vehicle allow enough access so that you can gain access to the aux power socket 2-way connector and disconnect.

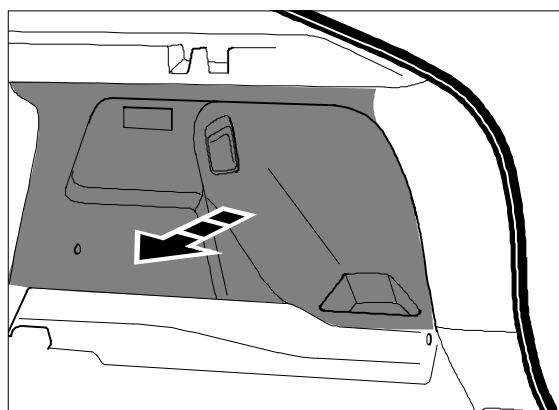

18. Locate and remove the vehicle \varnothing 25mm blanking plug on the RHS well.

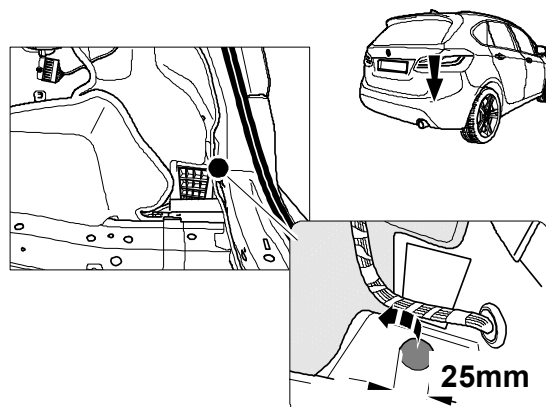



TOWBAR INSTALLATION INSTRUCTIONS

PART NUMBER 03340RW

BMW X2 F39 CL4

19. Drill out the hole to $\varnothing 30\text{mm}$.
20. From outside route the tail (1800mm) along the towbar and feed the tail blue connector through the previously drilled hole.
Slide the tail grommet to desired location ensure the grommet is seated properly.

Note: Remove all sharp edges and spray rust inhibitor.

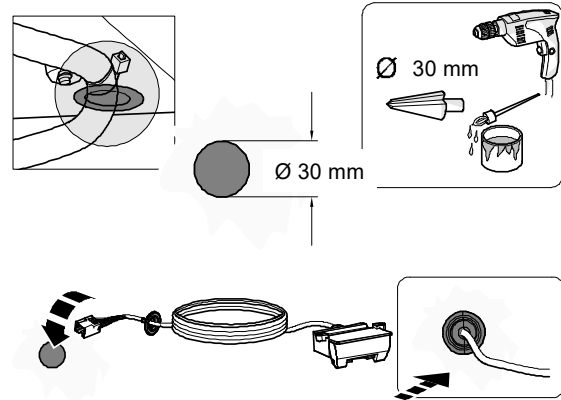

21. Plug the trailer module (WLE70019)
Please notice the insulation must be cut through in order to adhere the module against the sheet metal.

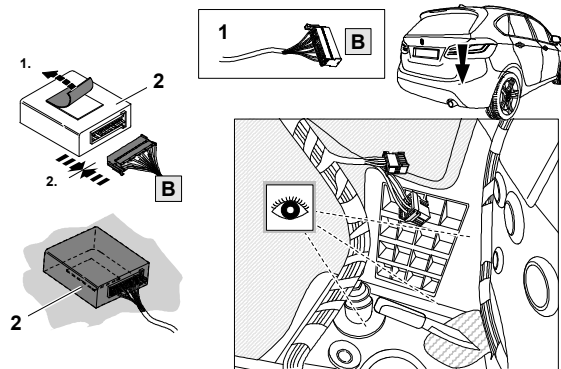

22. On the RHS rear of the vehicle locate the 6 and 10-way trailer prep connector which is taped back to main harness connect the 6-way Power ground connector to the trailer patch mating connector.

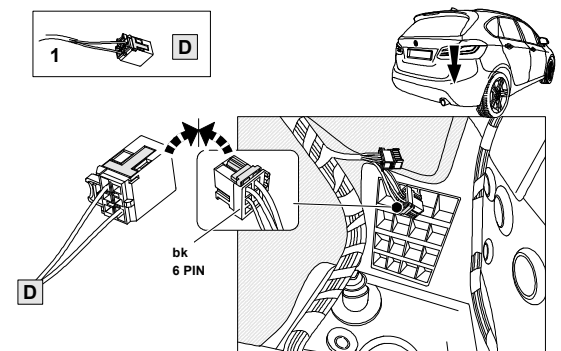



TOWBAR INSTALLATION INSTRUCTIONS

PART NUMBER 03340RW

BMW X2 F39 CL4

23. Locate the vehicle the 10 pin CAN connector with a jeweller's screwdriver release the secondary lock tab, press down on the terminal locking tang to release the terminal and remove the following wires:

PIN 2 = black/yellow

PIN 3 = yellow/red

PIN 4 = yellow/brown

Note: Ensure the terminals don't short out.

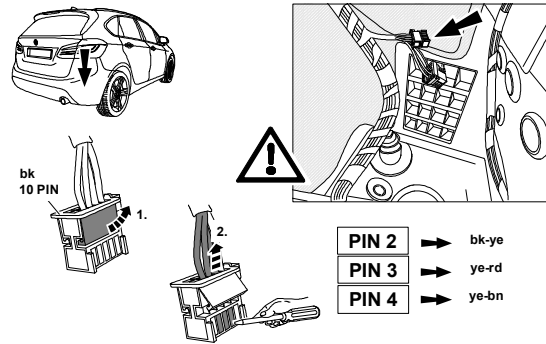

24. Close the secondary lock on the connector

25. Locate the 3-way female connector in the accessories bag of the trailer patch and insert the previously removed terminals in the pin orientation as below:

PIN 1 = yellow/red

PIN 2 = black/yellow

PIN 3 = yellow/brown

26. Close the secondary lock.

Note: The connector secondary locking tab should be in open state, if not use a jeweller's screw driver to open the tab.

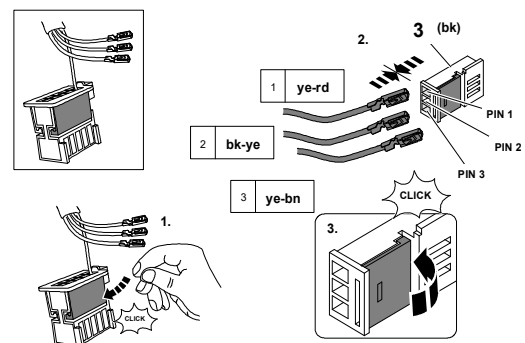

27. Locate and connect the 3-way female connector to the 3-way male connector on the trailer patch.

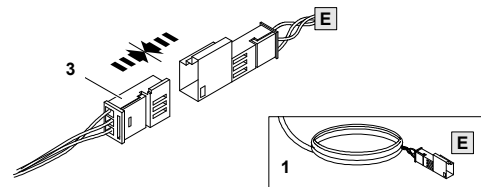

28. Locate an appropriate position on the bumper for the plug bracket. Ensure harness cable is long enough. Drill 2x \varnothing 5mm holes 69mm apart. Insert plug bracket through drilled holes. Attach trailer plug to plug bracket as shown using nuts supplied.

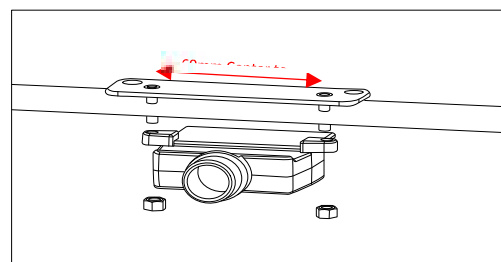



TOWBAR INSTALLATION INSTRUCTIONS

PART NUMBER 03340RW

BMW X2 F39 CL4

**BRAKE
CONTROLLER
PREPARED**

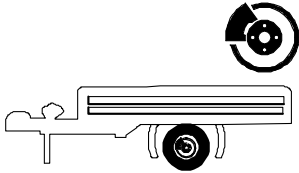

Trailer Brake Preparation

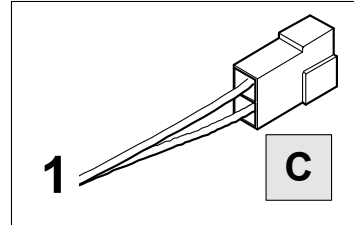

1.

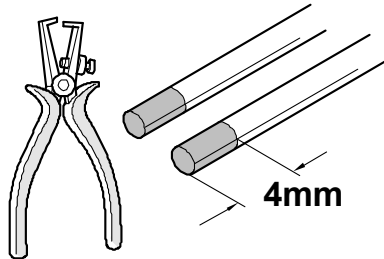

2.

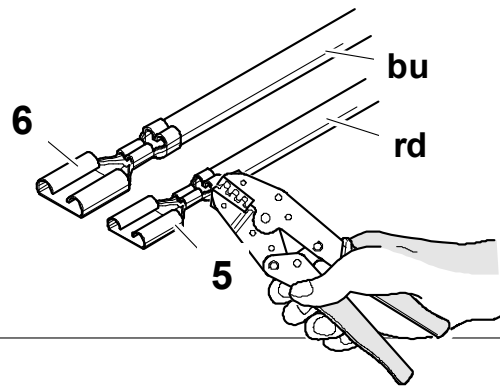

3.

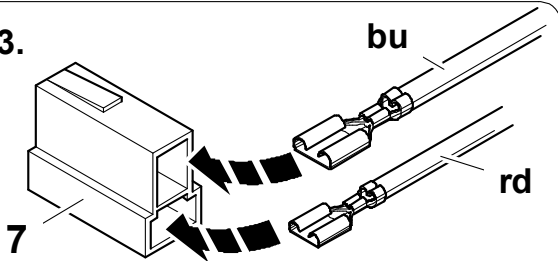

4.

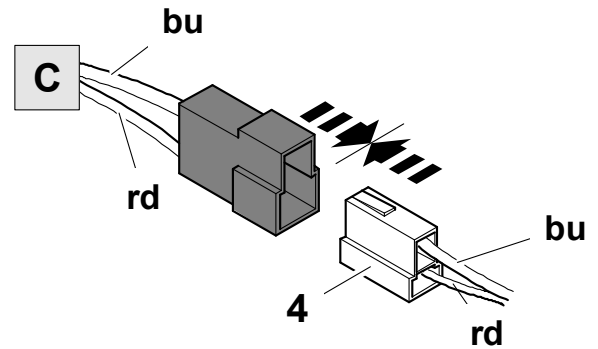

4

5

6

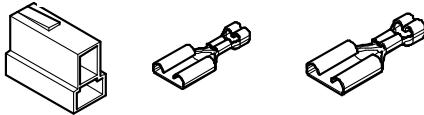



CUSTOMER INFORMATION

PLACE THESE INSTRUCTIONS IN THE
VEHICLE'S GLOVEBOX AFTER INSTALLATION

**THANK YOU FOR PURCHASING HAYMAN REESE.
WITH CORRECT MAINTENANCE AND CARE THIS PRODUCT WILL PROVIDE A
LIFETIME OF TROUBLE-FREE OPERATION.**

i TOWBAR MAINTENANCE AND CARE:

1. Hayman Reese recommend that the towbar LUG or TBM (tow ball Mount) Pull Pin and R-clip are removed and stored when not in use. Removal of LUG or TBM (tow ball mount) is advisable when not in use to assist with any of the following.
 - Ensure rear number plate is not obscured.
 - Allow maximum available departure angle and prevent any potential interference.
 - Prevent possible interference with vehicles reverse sensors or camera detecting a tow ball mount as an obstruction during reversing.
 - Removes towball mount as an obstruction for when moving around the rear of the vehicle.
2. Hayman Reese recommends routine inspection of your towbar to ensure trouble free towing.
 - Bolt security and tension should be regularly inspected and checked for correct tension. Replace any worn or defective parts with suitable grade & class fasteners. Inspection should be requested to coincide with vehicle major services.
3. It is the owner's responsibility to ensure towing and down ball weight capacities of the towing vehicle are not exceeded.
 - Towing and down ball weights allowable may differ according to model variations. Please refer to owner's manual or vehicle dealer to confirm exact rating for your vehicle model variant.
 - It is not uncommon for the vehicle tow rating to differ from the towbar rating. When this occurs, the lesser rating must be adhered to.
 - For vehicles fitted with enhanced vehicle functions that may be altered/changed when towing i.e Trailer sway mitigation, blind spot detection, adaptive cruise control etc. Please consult owner's manual to understand changes enabled when towing and after towing.

i WARRANTY INFORMATION:

Hayman Reese Towbars are covered by a Lifetime Warranty.

Our goods come with guarantees that cannot be excluded under the Australian Consumer Law. You are entitled to a replacement or refund for a major failure and for compensation for any other reasonably foreseeable loss or damage. You are also entitled to have the goods repaired or replaced if the goods fail to be of acceptable quality and the failure does not amount to a major failure.

For further details please visit www.haymanreese.com.au/warranty or contact customer service on 1800 812 017 or info@haymanreese.com.au.



CUSTOMER INFORMATION

PLACE THESE INSTRUCTIONS IN THE VEHICLE'S GLOVEBOX AFTER INSTALLATION

HAYMAN REESE SMART PIN

Your Hayman Reese towbar is equipped with Smart Pin technology to help reduce towbar tongue rattle in most driving conditions. Please ensure below instructions are understood and routine maintenance is carried out to ensure best towing experience.

i Regularly inspect for wear and check the tightness of the Smart Pin Nut. Follow instructions below to re-tighten the nut as necessary when movement and noise in the tow ball mount is noted.

- Before towing, ensure R-Clip is properly installed and Smart pin nut is installed and tensioned. Replacement parts are available from your Hayman Reese Distributor.

TOWBALL MOUNT REMOVAL/INSTALLATION

STEP 1

Insert Trailer Ball Mount (TBM) (a) into towbar hitchbox (b), aligning hole in TBM shank (c) with hole in hitchbox (d) (Fig. 1)

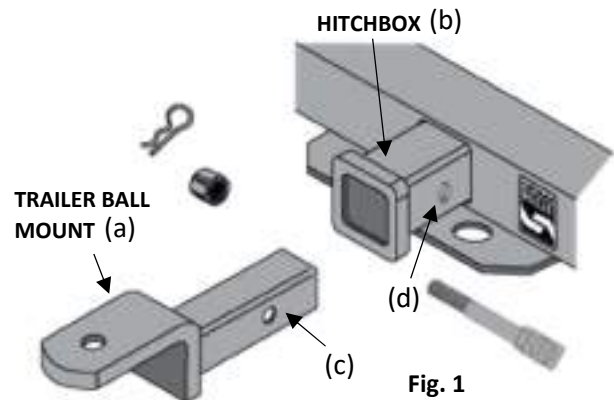

STEP 2

Insert Smart Pin (e) through hole in hitchbox and hole in TBM shank (g); ensure the locators are inserted into the notches in the hitchbox (Fig. 2)

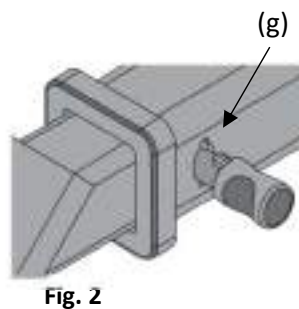

STEP 3

Screw Smart Pin Nut (f) onto Smart Pin (g); tighten Smart Pin Nut until finger tight, ensuring TBM is restrained from up and down movement.

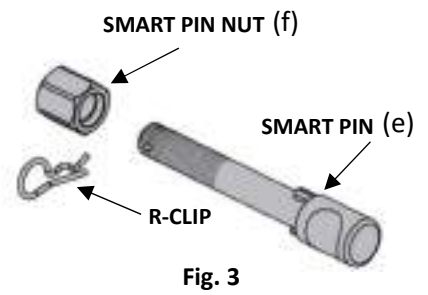

STEP 4

Tighten Smart Pin Nut by turning nut a further 1/8th of a turn in the clockwise direction using a 24mm spanner (Fig. 4).

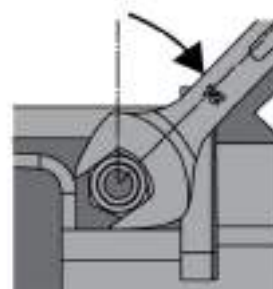

STEP 5

Install Smart Pin R-Clip through the hole that provides best clearance or easiest access. (Fig. 5)

