

HAYMAN REESE
PART No: 03169RW
BMW X1 F48
INSTALLATION INSTRUCTIONS

PLEASE ENSURE THAT INSTRUCTIONS ARE UNDERSTOOD PRIOR TO FITMENT
PLACE THESE INSTRUCTIONS IN THE VEHICLE'S GLOVEBOX AFTER INSTALLATION IS COMPLETED



Installation Time: Approx 60 Mins

Towbar Installation Instructions

Towbar capacity

BMW X1 F48

Part Number 03169RW

Max Towing Braked 2000 kg

Max Towing Unbraked 750 kg

Max Static Ball Load 80 kg

Hayman Reese (Cequent)
PO Box 4050, Dandenong South VIC 3164
Phone 1800 812 017 Email info@haymanreese.com.au

www.haymanreese.com.au



HAYMAN REESE

PART No: 03169RW

BMW X1 F48

INSTALLATION INSTRUCTIONS

PLEASE ENSURE THAT INSTRUCTIONS ARE UNDERSTOOD PRIOR TO FITMENT
PLACE THESE INSTRUCTIONS IN THE VEHICLE'S GLOVEBOX AFTER INSTALLATION IS COMPLETED

Warning:

1. Do not, drill, cut, weld or otherwise modify the towbar.
2. If you are using electric welding on a motor vehicle, **always** check that the vehicle is not equipped with electronic engine or instrument management equipment. Failure to do so could **destroy** any on board computers. If in doubt, check with the vehicle's manufacturer.
3. If TBM is used in inverted position tow ball may make contact with rear tailgate when lowered, which could cause damage.

General:

1. Ensure all hardware items have been included refer to assembly diagram.
2. It is recommended that the instructions are read through and completely understood before making any attempt to fit this product.
3. Be wary of any changes to vehicle designs or other accessories that may conflict with the installation of this product.
4. Before drilling ensure that the area is clear of fuel, electrical & other components.
5. All holes drilled into the body panels shall have all burrs & swarf removed then coated with a suitable rust preventative paint.
6. The high tensile fasteners supplied with this product were used to achieve the specified rating. If replacement is required ensure that fasteners of the same rating & quality are used. Contact an authorised **Hayman Reese** dealer if further information is required.
7. Ensure that all hardware is fastened to torque list below check fasteners on regular basis.
8. Towbar load rating sticker provided with this product shall be conspicuously located on inside rear end of the driver's door. **(See diagram below).**
9. Hayman Reese recommends that you check your tow ball to ensure that it complies with the Australian standards **AS 4177.2**.
10. **PLEASE NOTE:** It is advised to remove your LUG or TBM when not actually towing so as to produce a clear view of the vehicles registration plate if obscured, and to also provide maximum available departure angle.

Tow bar Maintenance and Care.

Hayman Reese recommends that bolt torque's, as listed below, are routinely and regularly inspected and checked for correct tension. Replace any worn or defective parts.

We recommended to remove Tow Ball Mounts (TBM's, tongues or lugs) when not being used for any considerable length of time.

So as to avoid injury, when not towing it is suggested that the tongue, Pull Pin and R-clip are removed then stored in a safe, clean and dry place, away from excessive moisture.

Hitch Pull Pins and spring "R" clips are regularly checked for proper installation. Replace any worn or defective parts.

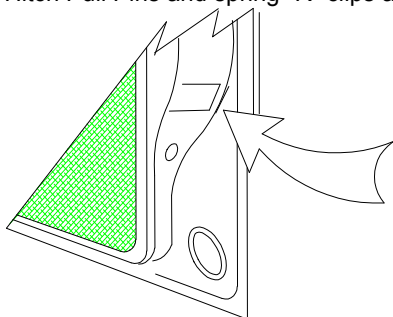

Place load rating sticker
inside driver's door here

RECOMMENDED ASSEMBLY TORQUE LISTING

Diameter Grade 8.8 Bolt

M6	9.5 Nm
M8	21.7 Nm
M10	43.4 Nm
M12	77.3 Nm
M14	146 Nm
M16	189.8 Nm

FOR TOWING PURPOSES ONLY

For towing capacity details please refer to vehicle owner's manual or to the manufacturer. Overloading can void your warranties.

Hayman Reese (Cequent)
PO Box 4050, Dandenong South VIC 3164
Phone 1800 812 017 Email info@haymanreese.com.au

www.haymanreese.com.au



HAYMAN REESE
PART No: 03169RW
BMW X1 F48
INSTALLATION INSTRUCTIONS

PLEASE ENSURE THAT INSTRUCTIONS ARE UNDERSTOOD PRIOR TO FITMENT
 PLACE THESE INSTRUCTIONS IN THE VEHICLE'S GLOVEBOX AFTER INSTALLATION IS COMPLETED

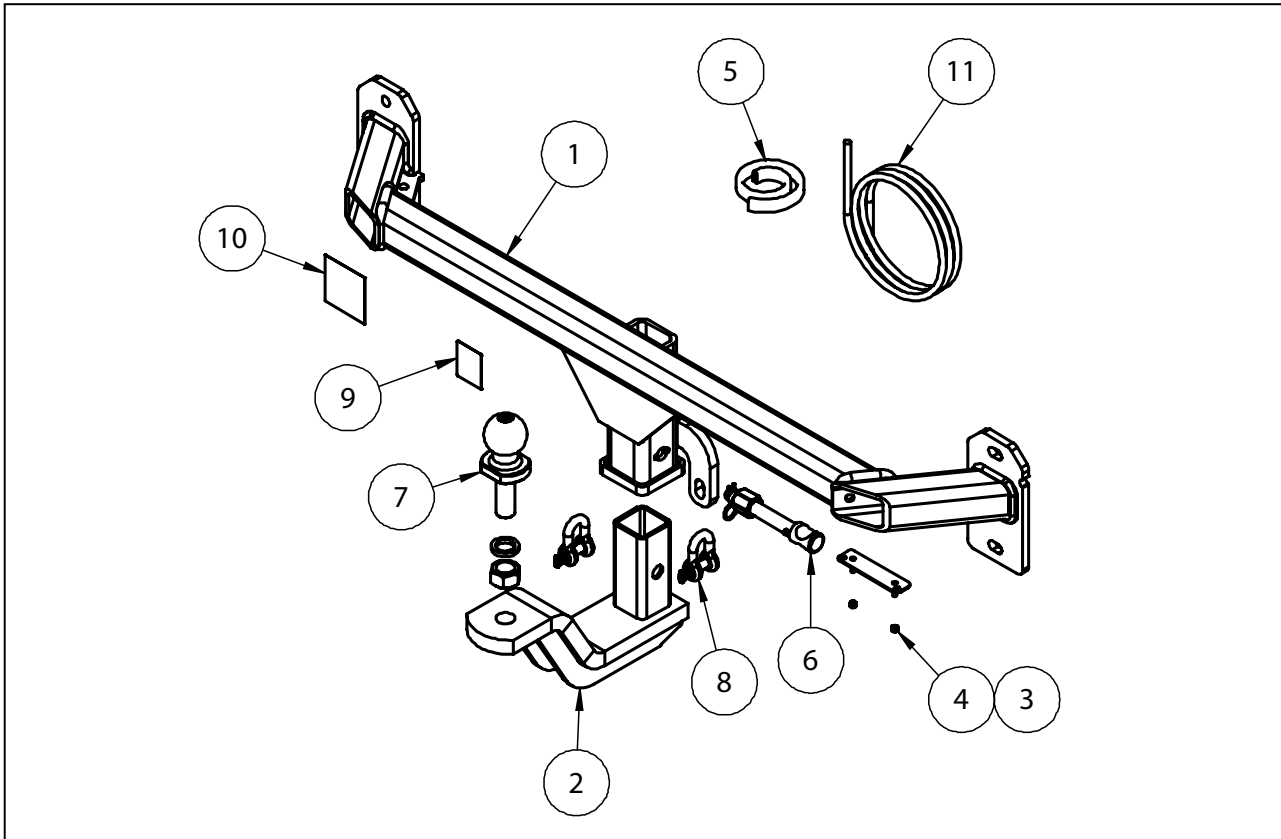

ITEM NO	DESCRIPTION	QTY.
1	BMW X1 F48 WELDED ASSEMBLY	1
2	TBM ASY	1
3	PLUG BRACKET	1
4	NUT NYLOC M4-0.7 Z/P	2
5	BUMPER TRIM PINCH WELD 400mm	1
6	ANTI-RATTLE PULL PIN ASSSY GOLD	1
7	HR TOWVALL	1
8	10mm "D" SHACKLE	2
9	H.R STICKER	1
10	ACRYLIC COMPLIANCE PLATE	1
11	VEHICLE-TRAILER WIRING HARNESS	1

Hayman Reese (Cequent)
 PO Box 4050, Dandenong South VIC 3164
 Phone 1800 812 017 Email info@haymanreese.com.au

www.haymanreese.com.au



HAYMAN REESE
PART No: 03169RW
BMW X1 F48
INSTALLATION INSTRUCTIONS

PLEASE ENSURE THAT INSTRUCTIONS ARE UNDERSTOOD PRIOR TO FITMENT
PLACE THESE INSTRUCTIONS IN THE VEHICLE'S GLOVEBOX AFTER INSTALLATION IS COMPLETED

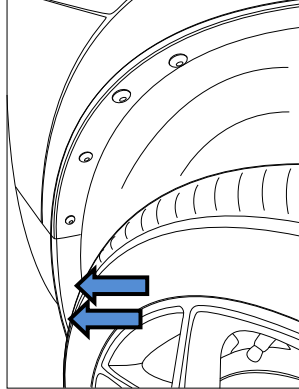
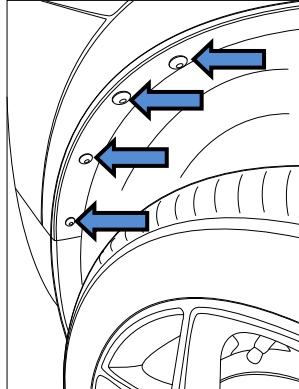
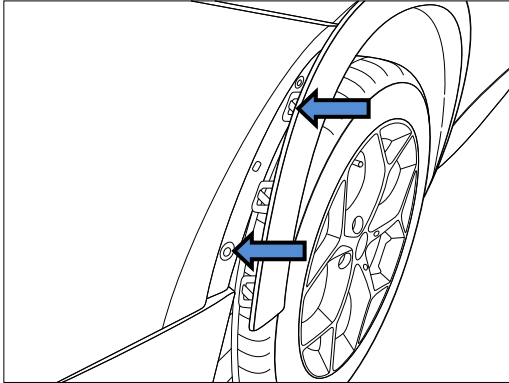
<p>1. Remove 2x Screws from rear face of rear wheel arch.</p> <p>Repeat for opposite side of vehicle.</p>	 A line drawing of the rear wheel arch area of a vehicle. Two blue arrows point to two screws located on the rear face of the wheel arch.
<p>2. Remove 4x push Rivets from rear wheel arch.</p> <p>Repeat for opposite side of vehicle.</p>	 A line drawing of the rear wheel arch area of a vehicle. Four blue arrows point to four push rivets located on the rear face of the wheel arch.
<p>3. Remove 2x Screws behind the rear face of the wheel arch trim.</p> <p>Repeat for opposite side of vehicle.</p>	 A line drawing of the rear wheel arch area of a vehicle, showing the wheel and arch trim. Two blue arrows point to two screws located behind the rear face of the wheel arch trim.

Hayman Reese (Cequent)
PO Box 4050, Dandenong South VIC 3164
Phone 1800 812 017 Email info@haymanreese.com.au

www.haymanreese.com.au



HAYMAN REESE
PART No: 03169RW
BMW X1 F48
INSTALLATION INSTRUCTIONS

PLEASE ENSURE THAT INSTRUCTIONS ARE UNDERSTOOD PRIOR TO FITMENT
PLACE THESE INSTRUCTIONS IN THE VEHICLE'S GLOVEBOX AFTER INSTALLATION IS COMPLETED

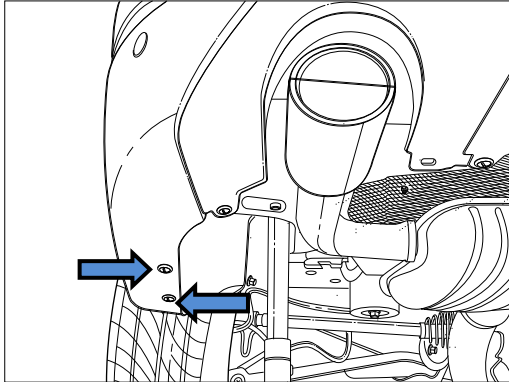
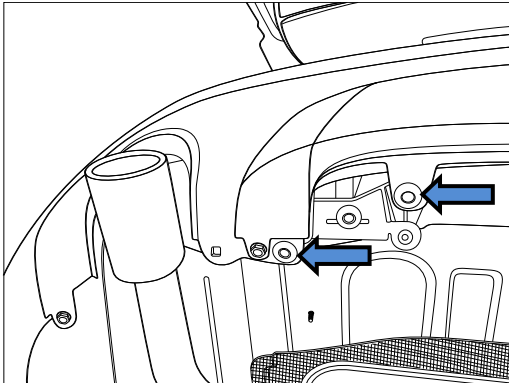
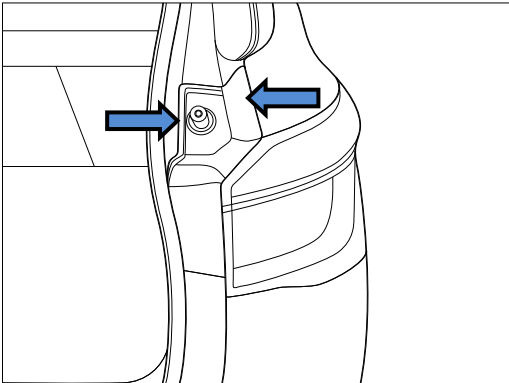
<p>4. Remove 2x Screws from underside of bumper, just below the wheel arch.</p> <p>Repeat for opposite side of vehicle.</p>	
<p>5. Remove 2x Screws from underside of bumper, at the left-rear end of vehicle.</p> <p>Repeat for opposite side of vehicle.</p>	
<p>6. Remove the trim adjacent to the tail light assembly within boot cavity, by first removing the plastic screw and plastic butterfly.</p> <p>Repeat for opposite side of vehicle.</p>	

Hayman Reese (Cequent)
PO Box 4050, Dandenong South VIC 3164
Phone 1800 812 017 Email info@haymanreese.com.au

www.haymanreese.com.au



HAYMAN REESE
PART No: 03169RW
BMW X1 F48
INSTALLATION INSTRUCTIONS

PLEASE ENSURE THAT INSTRUCTIONS ARE UNDERSTOOD PRIOR TO FITMENT
PLACE THESE INSTRUCTIONS IN THE VEHICLE'S GLOVEBOX AFTER INSTALLATION IS COMPLETED

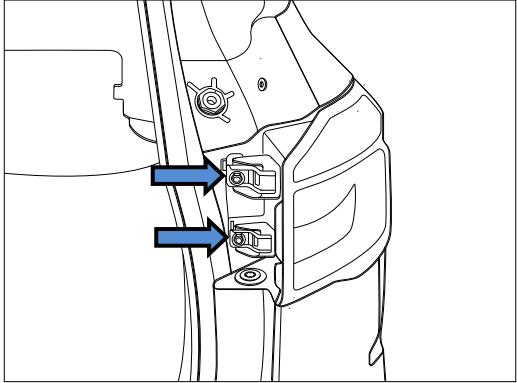
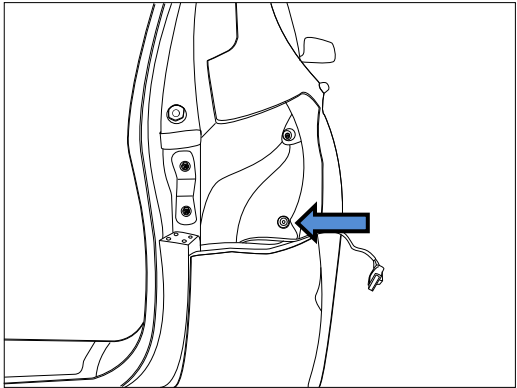
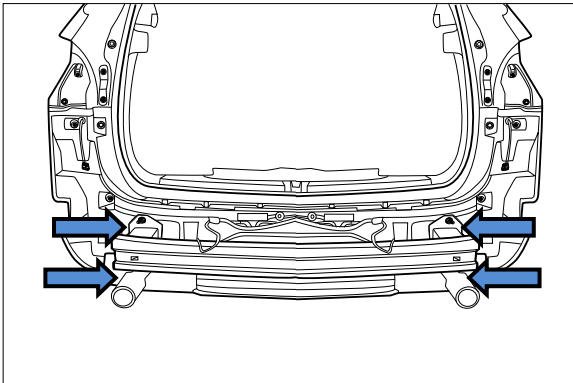
<p>7. Remove 2x Flanged Nuts securing tail light assembly. Remove and disconnect tail light assembly.</p> <p>Repeat for opposite side of vehicle.</p>	
<p>8. Remove Screw, previously concealed by tail light assembly.</p> <p>Repeat for opposite side of vehicle.</p> <p>9. Carefully unclip and remove bumper and disconnect 4x cable connectors.</p>	
<p>10. Remove and retain 4x Flanged Nuts securing rear impact beam.</p> <p>11. Remove and discard rear impact beam.</p> <p>12. Remove and discard 2x Rubber Pads</p>	

Hayman Reese (Cequent)
PO Box 4050, Dandenong South VIC 3164
Phone 1800 812 017 Email info@haymanreese.com.au

www.haymanreese.com.au



HAYMAN REESE
PART No: 03169RW
BMW X1 F48
INSTALLATION INSTRUCTIONS

PLEASE ENSURE THAT INSTRUCTIONS ARE UNDERSTOOD PRIOR TO FITMENT
PLACE THESE INSTRUCTIONS IN THE VEHICLE'S GLOVEBOX AFTER INSTALLATION IS COMPLETED

13. Where installed, disconnect remote boot and hands-free power tailgate sensor support. Remove 1x Flange screw on either end of the support. Disconnect clips and remove bracket.

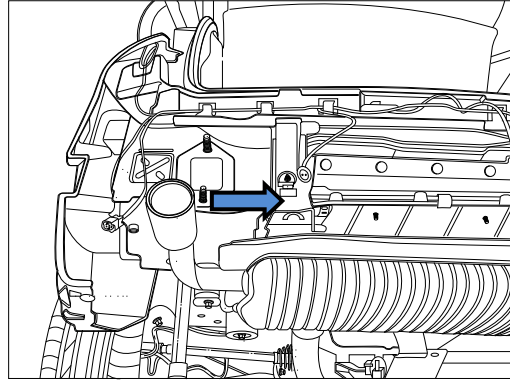

14. Offer Towbar to rear panel of vehicle. Secure Towbar with 4 x Flanged Nuts removed in step 9. Tighten flanged nuts to M12 torque specified on page 2 of this document.

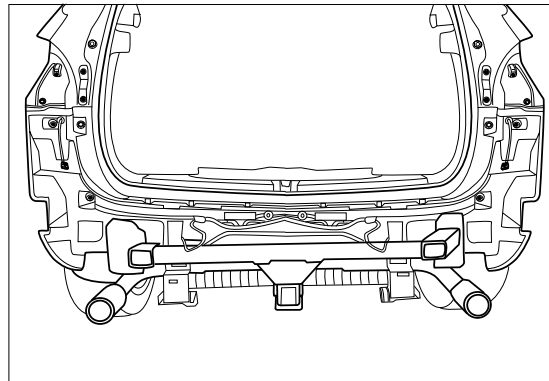

Hayman Reese (Cequent)
PO Box 4050, Dandenong South VIC 3164
Phone 1800 812 017 Email info@haymanreese.com.au

www.haymanreese.com.au



HAYMAN REESE
PART No: 03169RW
BMW X1 F48
INSTALLATION INSTRUCTIONS

PLEASE ENSURE THAT INSTRUCTIONS ARE UNDERSTOOD PRIOR TO FITMENT
PLACE THESE INSTRUCTIONS IN THE VEHICLE'S GLOVEBOX AFTER INSTALLATION IS COMPLETED

15. Mark out and drill 2x \varnothing 5mm holes 69mm apart on bumper skin to support plug bracket. Feed bracket threads through drilled holes prior to reinstalling bumper.

16. Reinstall bumper bar by following steps 1 to 13 in reverse order (excluding step 11).

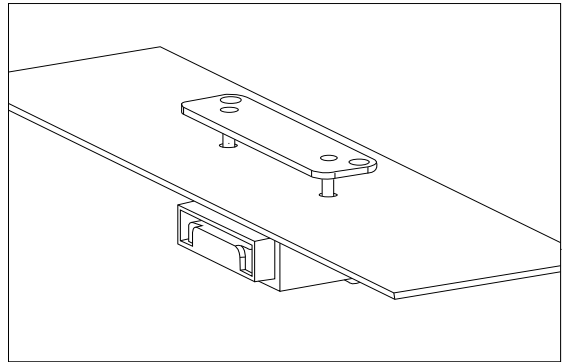
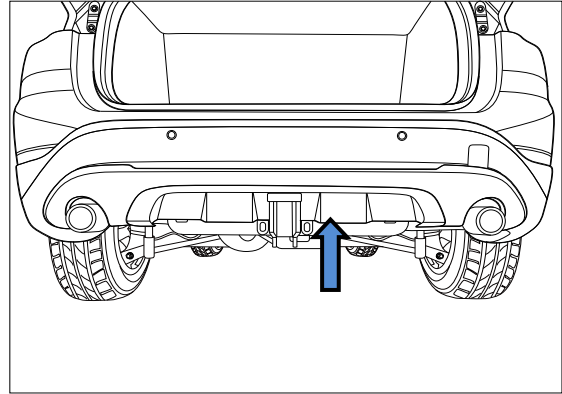

Hayman Reese (Cequent)
PO Box 4050, Dandenong South VIC 3164
Phone 1800 812 017 Email info@haymanreese.com.au

www.haymanreese.com.au



HAYMAN REESE
PART No: 101490-WL (03169RW)
BMW X1 F48

INSTALLATION INSTRUCTIONS

PLEASE ENSURE THAT INSTRUCTIONS ARE UNDERSTOOD PRIOR TO FITMENT

Wiring Loom Installation Instructions

BMW X1 F48

Part No: 101490-WL
ECU Required: 04838

Tail Harness Length Required: 1200mm

Wiring Loom Installation Time: Approx. 40 minutes

Important



Due to possible vehicle variations, always confirm any noted vehicle colour wires with a multi-meter to ensure the correct function is identified before soldering or scotch locking. For vehicle wires denoted with two colours (example; RED/GREEN) the first colour will always be the main wire colour while the second colour is the thinner trace colour on the wire.

Issue Date 20-06-16

Page 1

Part No: 101490-WL

Hayman Reese (Cequent)

PO Box 4050, Dandenong South VIC 3164

Phone 1800 812 017 Email info@haymanreese.com.au

www.haymanreese.com.au



HAYMAN REESE
PART No: 101490-WL (03169RW)
BMW X1 F48

INSTALLATION INSTRUCTIONS

PLEASE ENSURE THAT INSTRUCTIONS ARE UNDERSTOOD PRIOR TO FITMENT

1. Gain access to the rear of the vehicle, remove the luggage compartment rubber trim (1).
2. Remove the luggage compartment upper cover (2).

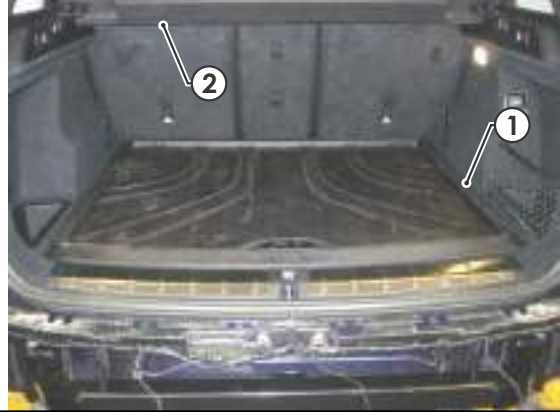

3. Remove luggage compartment floor trim (1).
4. Fold down the rear seats (2).



5. Remove the tool holder (1).
6. Remove the luggage compartment rear trim (2).
7. Remove the RHS compartment box (3).

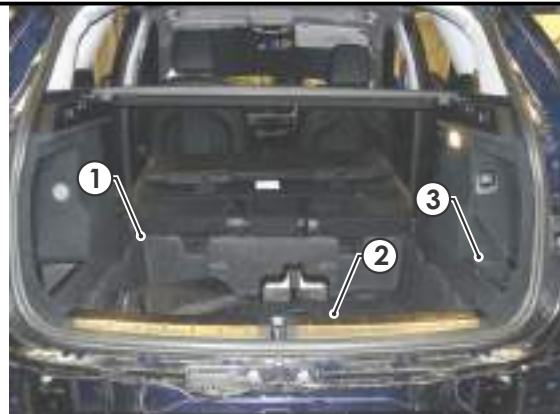

Issue Date 20-06-16

Page 2

Part No: 101490-WL

Hayman Reese (Cequent)
PO Box 4050, Dandenong South VIC 3164
Phone 1800 812 017 Email info@haymanreese.com.au

www.haymanreese.com.au



HAYMAN REESE
PART No: 101490-WL (03169RW)
BMW X1 F48

INSTALLATION INSTRUCTIONS

PLEASE ENSURE THAT INSTRUCTIONS ARE UNDERSTOOD PRIOR TO FITMENT

8. Remove the three fasteners (1) from the RHS compartment trim (2).

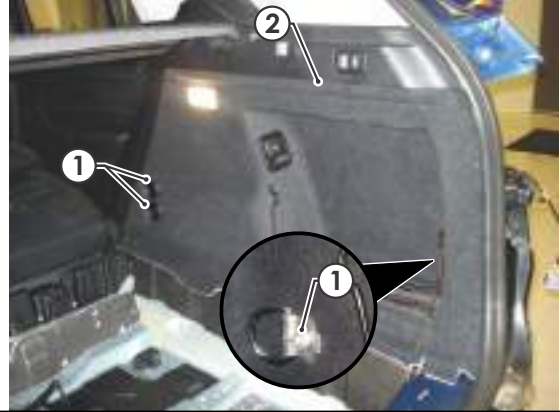

9. Dislodge the RHS compartment trim (1) enough to gain access to the breakout connector (2) behind.

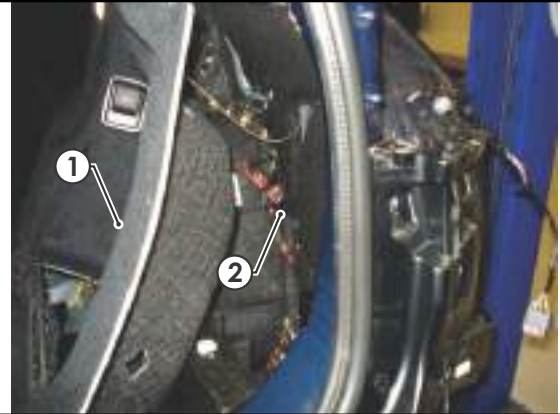

10. From the outside of the vehicle, drill a Ø30mm hole (1) in the area under the RHS tail lights.
11. File down any rough or sharp edges and spray on rust inhibitor (not included).
- Ensure there are no obstructions on the interior side before drilling.**

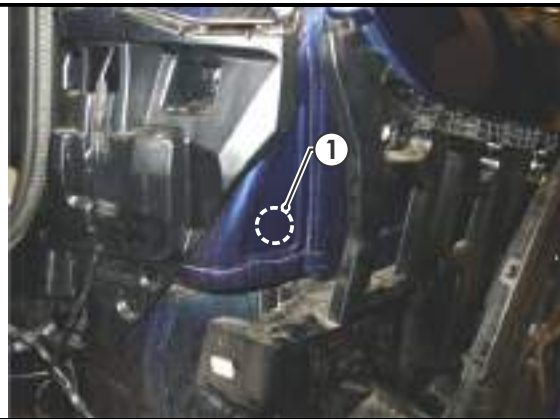

Issue Date 20-06-16

Page 3

Part No: 101490-WL

Hayman Reese (Cequent)
PO Box 4050, Dandenong South VIC 3164
Phone 1800 812 017 Email info@haymanreese.com.au

HAYMAN REESE
PART No: 101490-WL (03169RW)
BMW X1 F48

INSTALLATION INSTRUCTIONS

PLEASE ENSURE THAT INSTRUCTIONS ARE UNDERSTOOD PRIOR TO FITMENT

12. From inside the vehicle, move aside the insulation foam and route the vehicle harness (P/No: 101490-WL) through the previously drilled grommet hole.
13. Ensure the vehicle harness grommet is seated correctly.

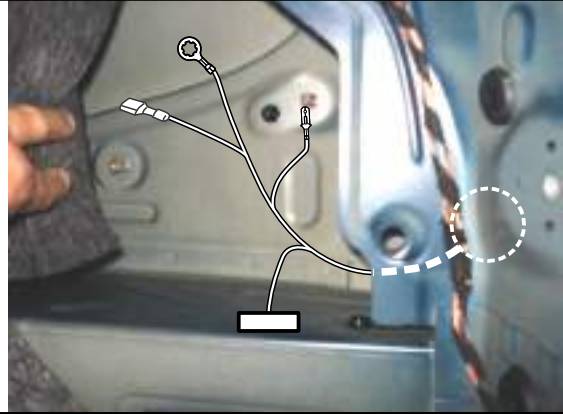

14. Locate the vehicle harness on the upper RHS.
 15. Following the table below, connect the ezy-tap (1) to the corresponding vehicle wire (2), then connect the trailer patch terminal (3) to the ezy-tap (1).
- Ensure the wire's used corresponds with the table below.**

Function	Trailer Patch	Vehicle Connector
REVERSE	BLACK / WHITE	GREY / BLUE

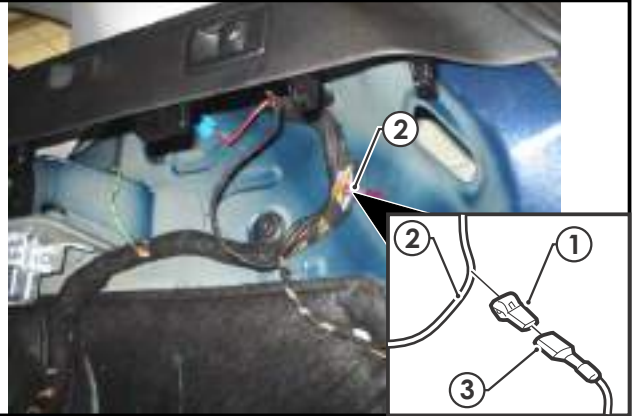

16. Locate the vehicle ground point as shown.
17. Connect the trailer harness ground ring terminal (2) to the vehicle ground stud (1).

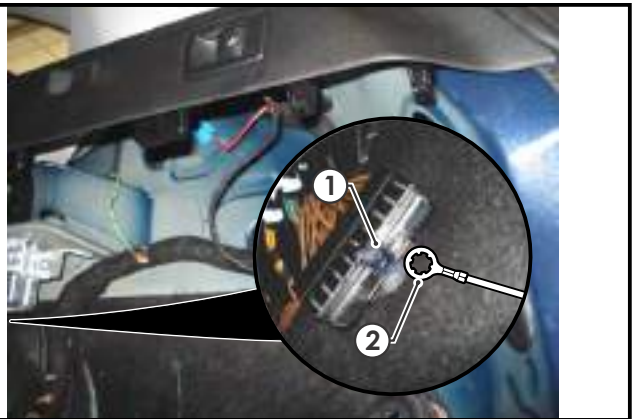

Issue Date 20-06-16

Page 4

Part No: 101490-WL

Hayman Reese (Cequent)
 PO Box 4050, Dandenong South VIC 3164
 Phone 1800 812 017 Email info@haymanreese.com.au

www.haymanreese.com.au



HAYMAN REESE

PART No: 101490-WL (03169RW)

BMW X1 F48

INSTALLATION INSTRUCTIONS

PLEASE ENSURE THAT INSTRUCTIONS ARE UNDERSTOOD PRIOR TO FITMENT

18. Insert the power wire terminal (1) on the trailer harness into the vehicle break out connector (2).

19. Route the power wire (3) back onto the vehicle break out connector (2) and secure using tape.

Make sure the power wire terminal and the connector is completely insulated.

Ensure the wire's used corresponds with the table below.

Function	Trailer Patch	Vehicle Connector
POWER	ORANGE	RED / YELLOW

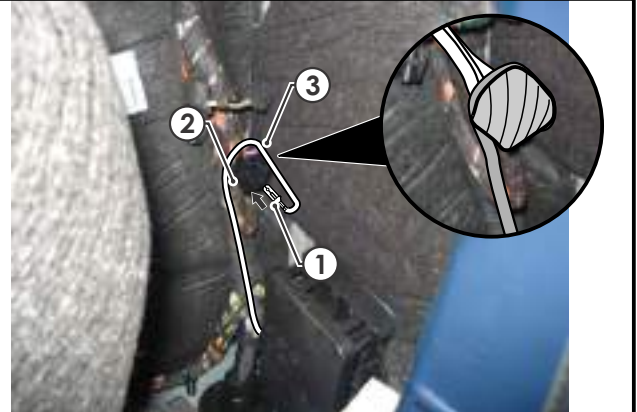

20. Connect the 12-way trailer harness connector (1) to the ECU (P/No:04838) (2).

21. Apply double tape to the ECU and mount as shown.

Ensure the mounting area is cleaned prior to mounting and that the ECU is mounted with the connector pointing downwards.

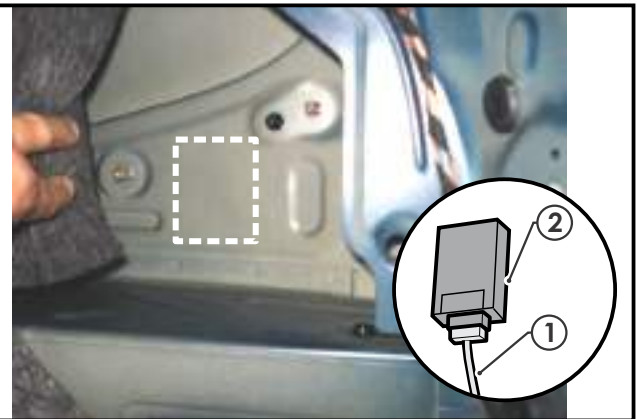

22. Route the trailer patch (1) (P/No: 101490-WL) connectors to the LHS and RHS of the vehicle.

23. Patch the LHS connector (2) to the vehicle mating tail light connector (3).

24. Patch the RHS connector (4) to the vehicle mating tail light connector (5).

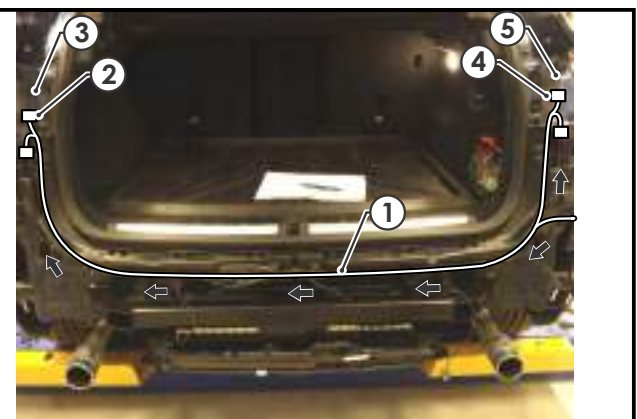

HAYMAN REESE
PART No: 101490-WL (03169RW)
BMW X1 F48

INSTALLATION INSTRUCTIONS

PLEASE ENSURE THAT INSTRUCTIONS ARE UNDERSTOOD PRIOR TO FITMENT

25. At the rear exterior of the vehicle, mount the tail harness socket (1) to the towbar mounting bracket using M4 fasteners (not supplied).
26. Route the tail harness (tail length: 1200mm) (2) across the RHS and up towards the trailer patch 8-way mating connector. Cable tie (not supplied) in place.

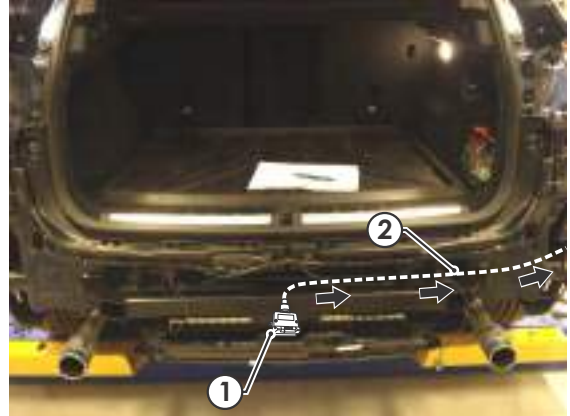

27. Connect the tail harness (tail length 1200mm) 8-way connector (1) to the trailer patch 8-way mating connector (2).
28. **Waterproof the trailer patch 8-way connector (1) and the tail harness 8-way male connector (2) using silicone or grease (3).**

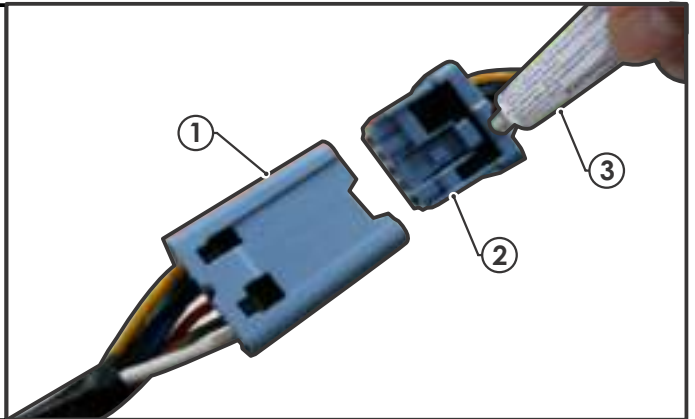

29. Refit tail lights.
30. Test the trailer patch function using a light board or multi-meter.
31. Secure all harnesses using cable ties (not supplied).
32. Re-fit all removed parts and secure all fasteners, ensuring there are no squeaks or rattles.
33. Place the fitting instructions in the glove box after fitment.
34. The park assist can be disabled via the switch (1) next to the gear shift.



Issue Date 20-06-16

Page 6

Part No: 101490-WL

Hayman Reese (Cequent)
PO Box 4050, Dandenong South VIC 3164
Phone 1800 812 017 Email info@haymanreese.com.au



FITTING INSTRUCTIONS

Smart Pin (55070BL)

• These fitting instructions are supplied to ensure understanding of how the SMART PIN should be fitted and used correctly.

• Once installed, we recommend **ALL** instructions are kept and placed in the vehicle glove box.

NOTE: Routine maintenance and inspection of the towbar & SMART PIN is required. Regularly inspect for wear and check the tightness of the SMART PIN NUT. Follow instructions below to retighten the nut when necessary.

***Do not tow with your vehicle if the R CLIP or the SMART PIN NUT is loose or missing. Replacement parts are available from your Hayman Reese Distributor.**

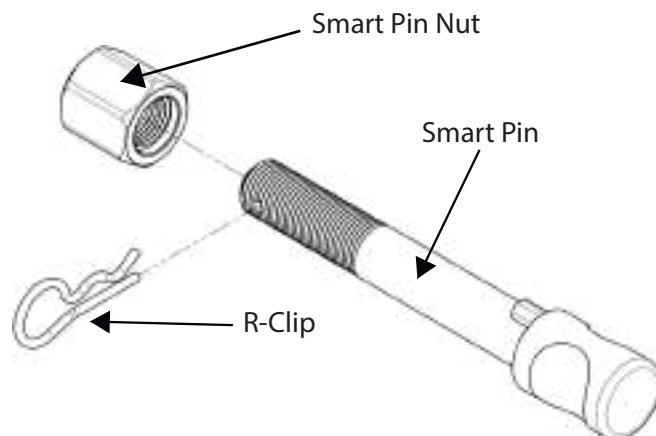
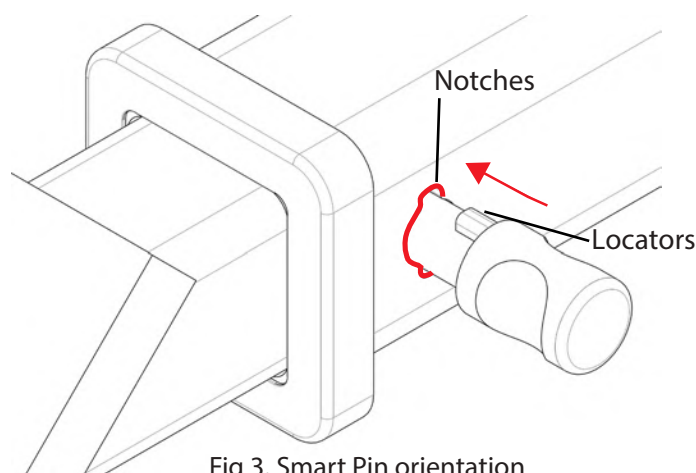
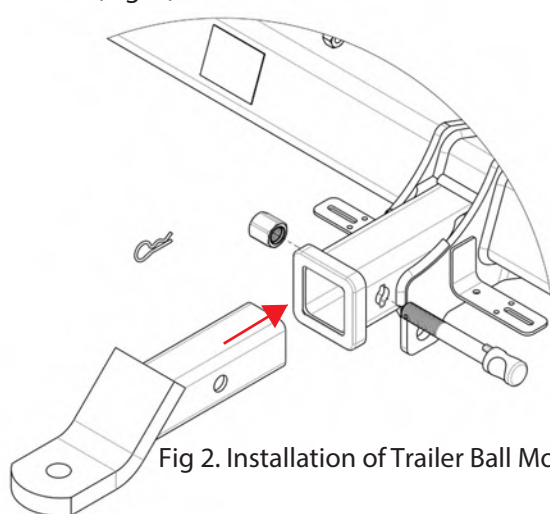

Fig 1. Smart Pin assembly

STEP 1 Insert Trailer Ball Mount (TBM) into towbar HITCHBOX, aligning hole in TBM SHANK with hole in HITCHBOX (Fig. 2).



STEP 2 Insert SMART PIN through hole in HITCHBOX and hole in TBM SHANK; ensure the LOCATORS are inserted into the NOTCHES in the HITCHBOX (Fig. 3).

STEP 3 Screw SMART PIN NUT onto SMART PIN; tighten SMART PIN NUT until finger tight, ensuring TBM is restrained from movement.

STEP 4 Tighten SMART PIN NUT by turning nut a further 1/8th of a turn in the clockwise direction using a 24mm spanner (Fig 4).

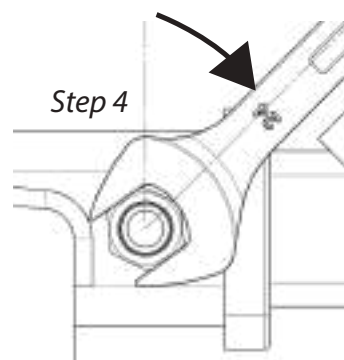

STEP 5 Install SMART PIN R CLIP through the hole on the SMART PIN (Fig. 1).

